

AGENDA - TOWN BOARD MEETING

April 9, 2020

7:30pm

REGULAR MEETING:

CALL TO ORDER

PLEDGE OF ALLEGIANCE

ROLL CALL

ACCEPTANCE OF MINUTES

1. Regular Meeting, March 26, 2020

CORRESPONDENCE:

MICHAEL SWEETON – Supervisor, Town of Warwick. Invitation and instructions to the Town of Warwick Residents to participate in a scheduled Zoom Meeting for the April 6, 2020 Town Board Meeting. *Zoom is requiring a password to join the meeting*

TYLER WREN – Founder & Principal of Farm to Fork. Email dated March 23, 2020 requesting their Special Event date be changes from June 14, 2020 to September 20, 2020.

SANDY BOURNE – Director of State Outreach, Mercatus Center at George Mason University. Email dated March 21, 2020 to the clerk regarding COVID-19 Pandemic Policy Responses: Temporary Lending Forms.

ALLISON WAGNER – Greenwood Lake Commission. Email dated March 21, 2020 to the Clerk regarding the Greenwood Lakes Commission's March 25, 202 meeting being postponed until April 1, 2020.

NEIL WINTER JR. – Orange & Rockland Utilities. Email dated March 23, 2020 to the Clerk regarding O&R, Rockland Electric Co. Expand efforts to protect public during Coronavirus Emergency – Focus on maintaining Safe, Reliable Service.

SANDY BOURNE – Director of State Outreach, Mercatus Center at George Mason University. Email dated March 27, 2020 to the Clerk regarding COVID-19 Pandemic Policy Response: Public-Private Virtual School Partnership and Federal Flexibility for Schools.

DAVID A. GETZ – P.E. Lehman & Getz Consulting Engineers. Letter dated March 23, 2020 to the Supervisor regarding Wise Equities LLC Property, Knights Lane, Wickham Lake Estates Subdivision L & G #2421.

KATIE TOMCZAK – Special Event Permit for the Richard Jacob Rudy Memorial Fund. A weekly Car Show to be held weekly May 7, 2020 – September 24, 2020 from 5:30pm – sunset at 580 Glenwood Road, Pine Island. All proceeds are donated to fund local families in need.

CARRIE SCALI – Planning Assistant, Orange County Planning Department. Email dated March 30, 2020 regarding Orange County Planning Departments services during the COVID-19 Pandemic.

DONNA L. LAVINS – Resident, Town of Warwick. Email dated March 27, 2020 to the Supervisor and Town Clerk regarding a variance notice the Points of View Association never received in regards to the Majewki gymnasium being built too close to Points of View Property.

NY DEPARTMENT OF STATE – Division of Building Standards and Codes. Email dated March 28, 2020 to the Clerk regarding the Annual Report of Code Enforcement Activities for Town of Warwick.

BENJAMIN D. ASTORINO – Commissioner, Town of Warwick DPW. Letter dated April 6, 2020 to the Supervisor regarding Knights Lane Request for road width reduction.

NEIL WINTER JR. – Orange & Rockland Utilities. Email dated March 27, 2020 to the Clerk regarding O&R, Rockland Electric Co. warning customers to beware scammers during the current Health Emergency.

ERMIN SILJKOVIC – Recycling Coordinator, Orange County DPW. Email to the Town Clerk dated April 1, 2020 regarding Hazardous waste collection event cancellation for Friday April 10, 2020 and Saturday April 11, 202 at the Thomas Bull Memorial Park.

VILLAGE OF WARWICK PLANNING BOARD – Notice of Intent to Re-establish Lead Agency for Warwick Commons Stage 5, LLC Amended Site Plan Approval, Brady Road, Warwick, NY.

OPTIMA ENVIRONMENTAL SERVICES – Letter received April 2, 2020 in the Clerks office informing the people that Optima Environmental Services will continue to provide essential and emergency services throughout this difficult time of the COVID-19 pandemic.

DAVID A. GETZ – P.E. Lehman & Getz Consulting Engineers. Letter dated March 23, 2020 to the Town Board and Supervisor regarding Wise Equities LLC Property Knights Lane, Wickham Lake Estates Subdivision L&G#2421.

BONNIE BECKER – Association of Towns. Email dated April 6, 2020 to the Town Clerk regarding Vol. 4 Association of Towns Legislative Newsletter.

NEIL WINTER JR. – Orange & Rockland Utilities. Email dated April 8, 2020 to the Clerk asking that residents please ALERT O&R of Emergency Work during the pandemic Crisis. Safety is the main concern.

BOARD’S DISCUSSION ON CORRESPONDENCE

VISITING ELECTED OFFICIALS

REPORTS OF BOARDS AND COMMISSIONS

COMMITTEE REPORTS

DEPARTMENT OF PUBLIC WORKS REPORT

Culvert Pipes	Bowen Rd.	Repair Box Culvert	Town
	Wheeler Rd.	Repair Box Culvert	Town
	Conklin Rd.	Repair Culvert Pipes	Town
Catch Basins	Wawayanda Ct.	Rebuild Basin	Town
Tree Work	Old Dutch Hollow Rd.	Remove dead Trees	Town
Pot Holes	Town Wide	Fill with Cold Patch	Town
	Village Wide	Fill with Cold Patch	Village of GWL
Sanding	Town	1/18 & 1/26 plow & sand all roads	Town
	Village	1/18 & 1/26 plow & sand all roads	Village of GWL
Vehicle Maint.	Town	As needed	Town
	Village	As needed	Village of GWL
Emerg. Repair	Town	As needed	Town
	Village	As needed	Village of GWL
Town Park	All Parks	Make New Signs (Social Distancing)	Town

PARKS DEPARTMENT

All Town Parks Open	Bathrooms Closed	Town
----------------------------	-------------------------	-------------

ENVIRONMENTAL CONSULTANTS REPORT

COUNCILMAN DE ANGELO REPORT

COUNCILMAN KOWAL REPORT

COUNCILMAN GERSTNER REPORT

COUNCILMAN SHUBACK REPORT

ATTORNEY'S REPORT

TOWN CLERK'S REPORT

1. FEES COLLECTED – March 2020

Interest in Town Clerk's Checking Account	\$.46
Wickham Woodland Manor Fee	\$150.00
Copy of Map	\$10.00
Film & Video Permit	\$250.00
Marriage Certified	\$90.00
Peddler Permit	\$200.00

Photocopies	\$2.25
Postage	\$1.40
Special Event Permit	\$50.00
Use of Room – Senior Center Kitchen	\$50.00
Dog Impoundments	\$375.00
Town Pavilion	\$175.00
Marriage License Fee	\$122.50
Conservation	\$9.65
Bell Jar	\$10.00
Dog Licenses	\$984.00
Use of Senior Room	\$60.00
Registrar Town of Warwick	\$140.00
Wickham Wedding Fee	\$30.00
Wickham Woodland Manor Deposit	\$300.00
Town Park Deposit	\$100.00
Total Local Shares Remitted	\$9,233.66

2. FEES PAID – March 2020

NYS Dept. of Health	\$157.50
NYS Ag & Markets for Spay/neuter program	\$126.00
NYS Environmental Conservation	\$165.35
NYS Comptroller Bell Jar	\$15.00
Village of Greenwood Lake for Registrar Fees	\$10.00
Village of Warwick for Registrar	\$1,170.00
Total Non-Local Revenues	\$1,643.85

3. *Bid Proposal for Fence Repair at the Thomas P. Morahan Waterfront Park*

- | | |
|---|--|
| <p>1. Kuperus Custom Fence, Inc.
 173 Hortons Road
 Westtown, NY 10998
 845-726-3849
 <u>Bid Proposal: \$1,850.00</u></p> | <p>2. A-Better Fence Co. Inc.
 135 Center Street
 West Milford, NJ 07480
 973-728-8222
 <u>Bid Proposal: \$2,275.00</u></p> |
| <p>3. Ketcham Fencing, Inc.
 19 Borden Street
 Ottisville, New York 10963
 845-386-1161
 <u>Bid Proposal: \$2,698.00</u></p> | |

4. ATTENTION VOTERS: ELECTION UPDATES

***The Presidential Primary will take place on June 23, 2020 NOT April 28, 2020. Polls will open at 6:00am until 9:00pm.**

***Mail Check Cards:** Please note that the yellow cards that were recently received by voters are sent out annually to verify voters' mailing addresses as a requirement of the NYS Election Law. These cards were sent to the post office by our printing vendor for mailing before we were notified of changes to the election calendar by Executive Order. Unfortunately, the cards were mailed to voters advising them of a Presidential Primary on April 28th which has since been moved to June 23rd.

***Presidential Primary Election Date Change:** The election date of the Democratic Presidential Primary was officially moved to June 23. The updated political calendar is attached where you can see the new dates for filing absentee ballots applications. This election will only contain the names of those individuals who had previously been qualified to appear on the ballot on April 28, 2020.

***State & Local Primary Information:** The date for this Primary is also June 23. Please note that we will have a Countywide Primary for the following offices: County Court Judge and Family Court Judge on the Conservative, Working Families, Green, Libertarian, Independence and SAM party lines. All towns will be involved and we expect to give you further information concerning this election in May.

***Village, School, Library Election Date Change:** Any school, library, or village election scheduled to take place in April or May of 2020 is hereby postponed until at least June 1, 2020, and subject to further directive as to the timing, location or manner of voting for such elections per Executive Order by the Governor.

***Independent Nominating Petitions:** Circulation, filing, and collection of any designating petitions, or independent nominating petitions for any office that would otherwise be circulated or filed pursuant to the Election Law, Education Law or any other consolidated law for any office commencing March 31, 2020 are hereby postponed.

We will keep you updated as things progress throughout this election season. Thank you for your patience and as always if you have any questions, please feel free to call 845-360-6500.

SUPERVISORS REPORT

- 1. Coronavirus Update**
- 2. Kutz Camp Update**
- 3. Journal entries**
- 4. Supervisors Corner – Published each week in the Warwick Dispatch, with excerpts printed in the Warwick Advertiser.**

PRIVILEGE OF THE FLOOR (AGENDA ITEMS)

NEW BUSINESS:

1. **AMEND #R2020-138 AUTHORIZE REFUND BUILDING PERMIT # 20190390**
2. **SPECIAL EVENT – FARM TO FORK FITNESS**
3. **APPROVE SPECIAL EVENT – RICHARD JACOB RUDY MEMEORIAL FUND (WEEKLY CAR SHOW)**
4. **ACCEPT BID PROPOSAL – REPAIR FENCE AT THOMAS P. MORAHAN WATERFRONT PARK**
5. **AUTHORIZATION TO SIGN 2019 SERVICE AWARD PROGRAM CERTIFICATE (LOSAP) – GREENWOOD LAKE VOLUNTEER AMBULANCE CORP.**
6. **AUTHORIZE SUPERVISOR TO SIGN EXTENSION OF LAND STEWARDSHIP AGREEMENT – ORANGE COUNTY LAND TRUST**
7. **APPROVE EAGLE SCOUT TRAIL PROJECT – THOMAS BOWMAN**
8. **APPROVE MODIFICATION OF ROAD – KNIGHTS LANE**
9. **KUTZ CAMP SEQR ASSESSMENT AND DETERMINATION**

BILLS:

PRIVILEGE OF THE FLOOR (GENERAL)

RECONVENE:

ADJOURN:

TOWN OF WARWICK



132 KINGS HIGHWAY
WARWICK, NEW YORK 10990

TOWN HALL TELEPHONE (845) 986-1124
POLICE DEPT. TELEPHONE (845) 986-3423
PUBLIC WORKS TELEPHONE (845) 986-3358
TOWN HALL FAX (845) 986-9908
SUPERVISOR msweeton@townofwarwick.org
TOWN CLERK clerk@townofwarwick.org

4-6-2020

Supervisor Michael Sweeton is inviting you to a scheduled Zoom meeting.

Topic: Warwick Town Board Meeting 4-9-2020

Time: Apr 9, 2020 07:30 PM Eastern Time (US and Canada)

Important, Please Note: Zoom is now requiring a password to join a meeting. If you wish to join you will have to enter the meeting ID noted below and then the password also note below. You will be placed into a virtual waiting room until the meeting is started. Every participant will also have their audio muted when they enter the meeting. The meeting will also be recorded and placed on www.townofwarwick.org by Friday morning 4-10-2020.

Join Zoom Meeting

<https://us04web.zoom.us/j/5837860184?pwd=OXR2VFBFdkVmMDJ2c2Vna2NjZTVpQT09>

Meeting ID: 583 786 0184

Password: 484373

One tap mobile

+13126266799,,5837860184# US (Chicago)

+19294362866,,5837860184# US (New York)

Dial by your location

+1 312 626 6799 US (Chicago)

+1 929 436 2866 US (New York)

+1 253 215 8782 US

+1 301 715 8592 US

+1 346 248 7799 US (Houston)

+1 669 900 6833 US (San Jose)

Meeting ID: 583 786 0184

Password: 484373

Find your local number: <https://us04web.zoom.us/j/5837860184>

Use of Cloth Face Coverings to Help Slow the Spread of COVID-19

How to Wear Cloth Face Coverings

Cloth face coverings should—

- fit snugly but comfortably against the side of the face
- be secured with ties or ear loops
- include multiple layers of fabric
- allow for breathing without restriction
- be able to be laundered and machine dried without damage or change to shape

CDC on Homemade Cloth Face Coverings

CDC recommends wearing cloth face coverings in public settings where other social distancing measures are difficult to maintain (e.g., grocery stores and pharmacies), **especially** in areas of significant community-based transmission.

CDC also advises the use of simple cloth face coverings to slow the spread of the virus and help people who may have the virus and do not know it from transmitting it to others. Cloth face coverings fashioned from household items or made at home from common materials at low cost can be used as an additional, voluntary public health measure.

Cloth face coverings should not be placed on young children under age 2, anyone who has trouble breathing, or is unconscious, incapacitated or otherwise unable to remove the cloth face covering without assistance.

The cloth face coverings recommended are not surgical masks or N-95 respirators. Those are critical supplies that must continue to be reserved for healthcare workers and other medical first responders, as recommended by current CDC guidance.

Should cloth face coverings be washed or otherwise cleaned regularly? How regularly?

Yes. They should be routinely washed depending on the frequency of use.

How does one safely sterilize/clean a cloth face covering?

A washing machine should suffice in properly washing a cloth face covering.

How does one safely remove a used cloth face covering?

Individuals should be careful not to touch their eyes, nose, and mouth when removing their cloth face covering and wash hands immediately after removing.

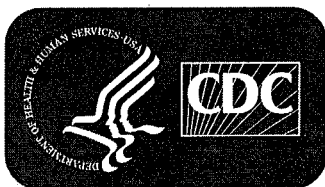
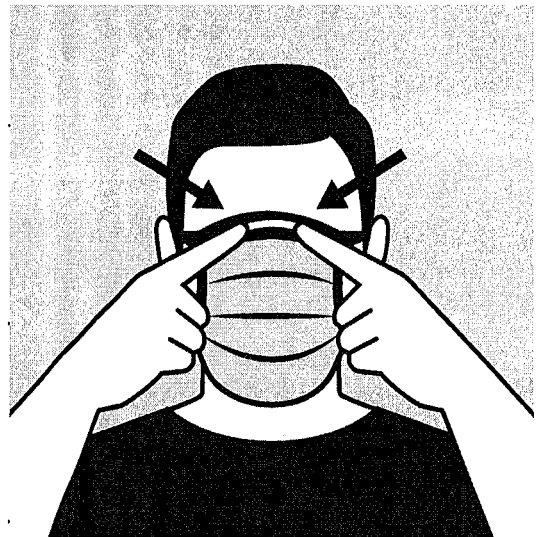
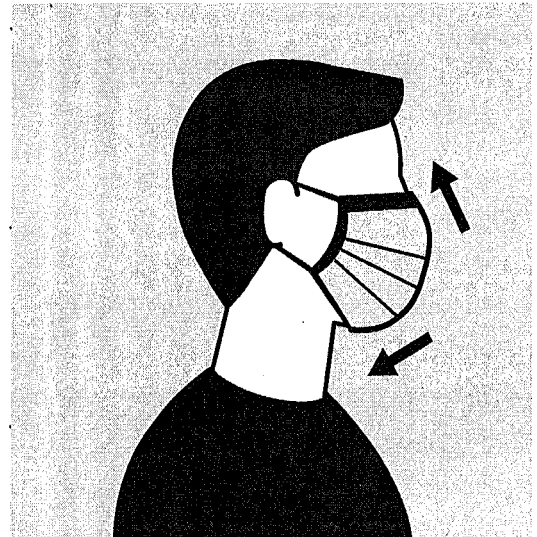

[cdc.gov/coronavirus](https://www.cdc.gov/coronavirus)

Sewn Cloth Face Covering

Materials

- Two 10"x6" rectangles of cotton fabric
- Two 6" pieces of elastic (or rubber bands, string, cloth strips, or hair ties)
- Needle and thread (or bobby pin)
- Scissors
- Sewing machine

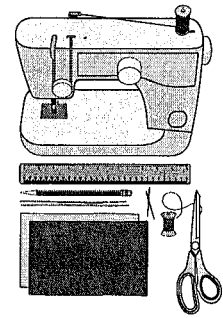

Tutorial

1. Cut out two 10-by-6-inch rectangles of cotton fabric. Use tightly woven cotton, such as quilting fabric or cotton sheets. T-shirt fabric will work in a pinch. Stack the two rectangles; you will sew the cloth face covering as if it was a single piece of fabric.

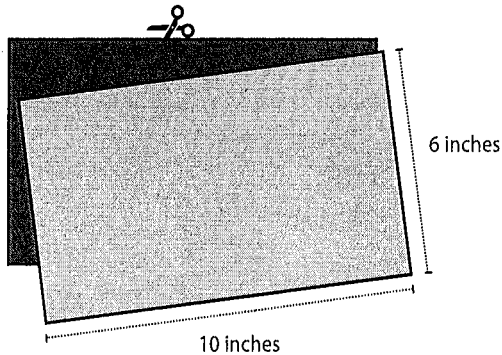

2. Fold over the long sides $\frac{1}{4}$ inch and hem. Then fold the double layer of fabric over $\frac{1}{2}$ inch along the short sides and stitch down.

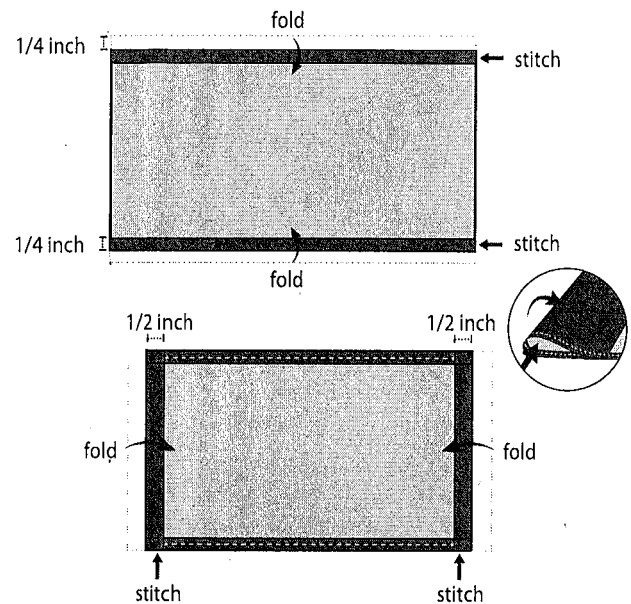

3. Run a 6-inch length of $\frac{1}{8}$ -inch wide elastic through the wider hem on each side of the cloth face covering. These will be the ear loops. Use a large needle or a bobby pin to thread it through. Tie the ends tight. Don't have elastic? Use hair ties or elastic head bands. If you only have string, you can make the ties longer and tie the cloth face covering behind your head.

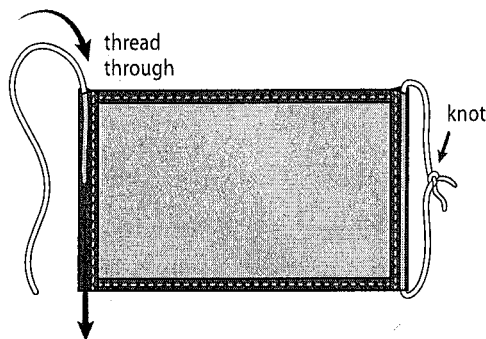

4. Gently pull on the elastic so that the knots are tucked inside the hem. Gather the sides of the cloth face covering on the elastic and adjust so the cloth face covering fits your face. Then securely stitch the elastic in place to keep it from slipping.

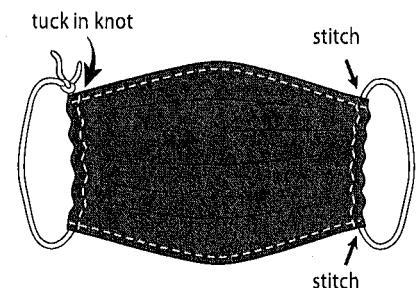

Quick Cut T-shirt Cloth Face Covering (no sew method)

Materials

- T-shirt
- Scissors

Tutorial

1.

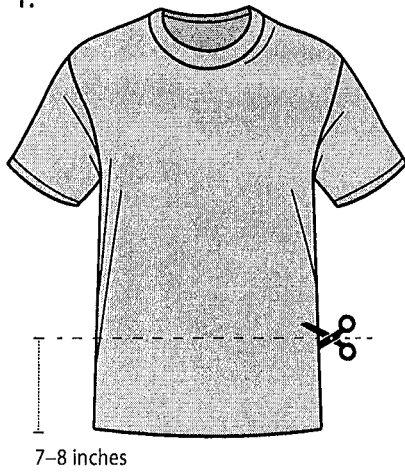

2.

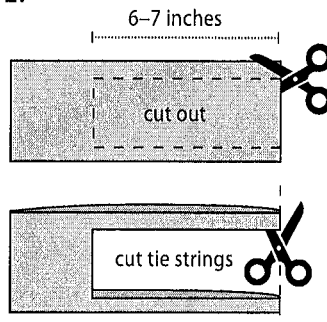

3.

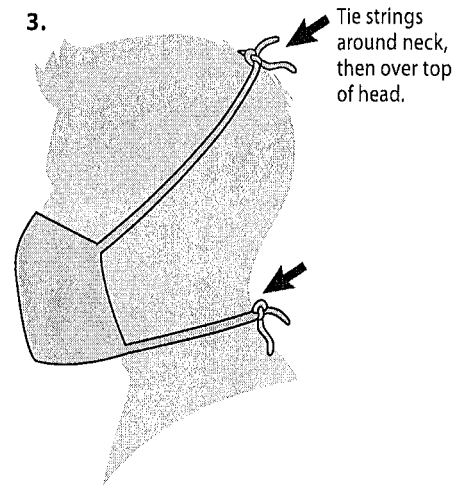

Bandana Cloth Face Covering (no sew method)

Materials

- Bandana (or square cotton cloth approximately 20"x20")
- Coffee filter
- Rubber bands (or hair ties)
- Scissors (if you are cutting your own cloth)

Tutorial

1.

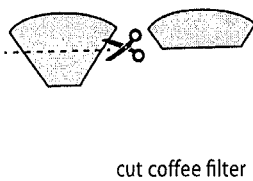

2.

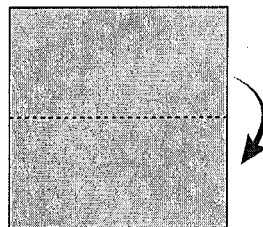

3.

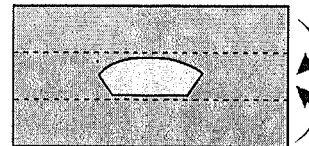

Fold filter in center of folded bandana.
Fold top down. Fold bottom up.

4.



Place rubber bands or hair ties about 6 inches apart.

5.

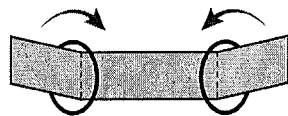

Fold side to the middle and tuck.

6.



7.



X

SEQR

Notice of Intent to Re-establish Lead Agency

This notification is for the purpose of re-designating a lead agency according to the requirements of Article 8 of New York State Environmental Conservation Law for the following proposed action:

Date: March 31, 2020

To: All Involved Agencies

From: Village of Warwick Planning Board
77 Main Street
Warwick, NY 10990
Orange County, NY
James Patterson, Chairman

RECEIVED
APR 02 2020
Town of Warwick
Town Clerk

Project Title: Warwick Commons Stage 5, LLC
Amended Site Plan Approval
Brady Road
Warwick, NY 10990

History - This application consisted of 309 units w/635 bedrooms in 1986. Lead Agency was first established by the Village of Warwick Planning Board on or before April 1986. An amended site plan was submitted for review and Lead Agency was re-established in January, 2010. In December of 2019 a new amended site plan was submitted to the Village Planning Board and this notice is to re-establish Lead Agency status.

Description of Proposed Action: 14 Buildings, 90 - 2-bedroom units each with proposing a 2-car garage and 2 parking spaces in driveway. 42 additional visitor parking provided throughout the site. Clustered mailboxes and trash/recycling enclosures on each internal roadway to service units.

This notification is being sent to involved agencies with the request that you consent to our agency serving as Lead Agency. If, however, you do not agree, you may follow the procedures outlined in 6NYCRR 617.6(b)(5).

Attachments to This Notice:

- 1) Short EAF
- 2) Narrative
- 3) Sketch Plan

A copy of this Notice is being sent to the following Involved Agencies:

Army Corp. of Engineers
New York District, Corps of Engineers
Jacob K. Javits Federal Building
26 Federal Plaza
New York, NY 10278-0090
Att: Brian Orzel

Town of Warwick ✓
132 Kings Hwy
Warwick, NY 10990

Village of Warwick
77 Main St.
Warwick, NY 10990

Orange County Dept. of Health
124 Main St.
Goshen, NY 10924

NYS DEC
21 South Putt Corners Rd.
New Paltz, NY 12561-1620



Engineers
Planners
Surveyors
Landscape Architects
Environmental Scientists

555 Hudson Valley Avenue, Suite 101
New Windsor, NY 12553-4749
T: 845.564.4495
F: 845.567.1025
www.maserconsulting.com

NARRATIVE SUMMARY
DECEMBER 20, 2019
WARWICKCOMMONS STAGE 5, LLC
TAX LOTS: 218-1-91, 92, 93, 94 & 96 and 219-1-2.2
VILLAGE OF WARWICK, ORANGE COUNTY, NY
PB#
MC PROJECT NO. 15002429D

Maser Consulting, P.A. (MC) has developed the attached Sketch Plan for the above referenced tax lots. This project received Amended Site Plan approval on May 17, 2012. Extensions of this approval are up to date.

The existing parcel is approximately 15.3 acres with frontage on Brady Road along its western boundary, Warwick Meadows HOA to the north, a residential subdivision on Ridgefield Road to the East, and a residential single-family property to the south. The site is located within the R (Residential) Zoning District where a Multiple-residence, is a use requiring a Special Use Permit. The proposed development is compliant with all zoning requirements except for Developmental Coverage. Under the prior approval, the site's Developmental Coverage was 65.7% or 233,064 sf. The current plan reduces the Developmental Coverage to 62.2% or 220,643 sf. This previously approved exceedance of the zoning code has been reduced for the current application.

The parcel is not located within a one-hundred-year flood plain and no NYSDEC wetlands exist on the project site. Federal wetlands do exist on the site. The extents of these Federal wetlands were re-flagged by Maser Consulting on July 26, 2019 and a Jurisdictional Determination is being sought from the Army Corps of Engineers to confirm the extents.

The previously approved plan proposed 15 buildings containing 116 residential units while the current Sketch Plan proposes a total of 14 buildings and 90 units (all 2-bedroom units). Each unit proposes a 2-car garage and 2 parking spaces in the driveway. There are an additional 42 visitor parking spaces provided throughout the site. Clustered mailboxes and trash/recycling enclosures are also provided on each of the internal roadways to service the units.

The internal roadway layout for the development has been revised to reduce the number of internal roadways servicing the development, and now provides either a through road, a cul-de-sac or a loop road to facilitate resident, deliveries, trash pickup, snow removal and emergency service circulation. The current plan removes dead end parking lots and stand-alone garage enclosures. The previous 6-way intersection at Brady Road has been removed for safety reasons.

All proposed lots will be accessible from Sheffield Drive (aka Magnolia Drive). The road and some utilities were partly built however the road has fallen into disrepair. It is proposed that the road will be built to the Village Road Specifications and will be dedicated upon completion.

On-site stormwater management will be provided as required per the Village and N.Y.S. Department of Environmental Conservation (NYSDEC). The development is proposed to be serviced by municipal water and sanitary sewer systems.



Customer Loyalty
through Client Satisfaction



Subsequent design plans shall include existing condition/demolition, layout and dimensional plans, grading and drainage, utility, erosion and sediment control, lighting, landscaping, profiles and details of construction.

A permit from the NYSDEC Dam Safety Division shall be sought to decommission the existing Class B dam. It is proposed to drain the pond, stabilize the soil, remove the concrete box (water control structure), support the existing utilities in Laudaten Way and install a culvert to convey the stream and carry Laudaten Way.

At this time, we are requesting to be put on the next available Planning Board agenda to discuss the current proposal for the project.

ABF/jed

VILLAGE OF WARWICK
PLANNING BOARD APPLICATION

Date _____

Application fee _____

1) Applicant's name Warwick Commons Stage 5, LLC
Address 321 Rte 59, #338 Tele: 845-291-0011 (Jay Myrow)
Tallman, NY 10982
2) Project Location Warwick Commons, Brady Rd
3) Section 218 Lot 1 Block 91-94
4) What action is the applicant seeking Amended Site Plan approval
5) Describe Proposed Project 90 unit multi-family development

6) Application For:

amended

A) Site Plan B) Preliminary Approval _____ C) Final Approval _____

D) Minor Subdivision _____ E) Major Subdivision _____ F) Conditional Use _____ Lot Line Change _____

7) Square Footage of Parcel 623,505

8) Have any variances or special permits been granted to the proposed property _____
If so please attach _____

Signatures must be notarized

Signature of Applicant [Signature] Date 12/30/19

Signature of Property Owner _____ Date _____

Notary Seal:

[Signature]
JAY R. MYROW
Notary Public, State of New York
No. 02MY6053208
Qualified in Orange County
Commission Expires January 8, 2023

Owner and/or applicant are responsible for payment of any and all consultant's fees.

Short Environmental Assessment Form

Part 1 - Project Information

Instructions for Completing

Part 1 – Project Information. The applicant or project sponsor is responsible for the completion of Part 1. Responses become part of the application for approval or funding, are subject to public review, and may be subject to further verification. Complete Part 1 based on information currently available. If additional research or investigation would be needed to fully respond to any item, please answer as thoroughly as possible based on current information.

Complete all items in Part 1. You may also provide any additional information which you believe will be needed by or useful to the lead agency; attach additional pages as necessary to supplement any item.

Part 1 – Project and Sponsor Information			
Name of Action or Project: Warwick Commons			
Project Location (describe, and attach a location map): Tax Lots 218-1-91,92,93,94&96 and 219-1-2.2 - see attached location map			
Brief Description of Proposed Action: See attached Project Narrative.			
Name of Applicant or Sponsor: Warwick Commons Stage 5, LLC (Attn: Nathan Ungar)		Telephone: 845-499-8073 E-Mail: NUSYNUNGAR@GMAIL.COM	
Address: 321 Route 59, #338			
City/PO: Tallman		State: New York	Zip Code: 10982
1. Does the proposed action only involve the legislative adoption of a plan, local law, ordinance, administrative rule, or regulation? If Yes, attach a narrative description of the intent of the proposed action and the environmental resources that may be affected in the municipality and proceed to Part 2. If no, continue to question 2.			NO <input type="checkbox"/>
2. Does the proposed action require a permit, approval or funding from any other government Agency? If Yes, list agency(s) name and permit or approval: Village of Warwick Planning Board Amended Site Plan and Special Use Permit, NYDEC Stormwater SPODES permit, Orange Department of Health Water Extension			YES <input checked="" type="checkbox"/>
3. a. Total acreage of the site of the proposed action? _____ 15.3 acres b. Total acreage to be physically disturbed? _____ +/-11.5 acres c. Total acreage (project site and any contiguous properties) owned or controlled by the applicant or project sponsor? _____ 15.3 acres			
4. Check all land uses that occur on, are adjoining or near the proposed action:			
5. <input type="checkbox"/> Urban <input type="checkbox"/> Rural (non-agriculture) <input type="checkbox"/> Industrial <input type="checkbox"/> Commercial <input checked="" type="checkbox"/> Residential (suburban) <input checked="" type="checkbox"/> Forest <input type="checkbox"/> Agriculture <input type="checkbox"/> Aquatic <input checked="" type="checkbox"/> Other(Specify): Wetland <input type="checkbox"/> Parkland			

5. Is the proposed action,	NO	YES	N/A
a. A permitted use under the zoning regulations?	<input type="checkbox"/>	<input checked="" type="checkbox"/>	<input type="checkbox"/>
b. Consistent with the adopted comprehensive plan?	<input type="checkbox"/>	<input checked="" type="checkbox"/>	<input type="checkbox"/>
6. Is the proposed action consistent with the predominant character of the existing built or natural landscape?	NO	YES	
	<input type="checkbox"/>	<input checked="" type="checkbox"/>	
7. Is the site of the proposed action located in, or does it adjoin, a state listed Critical Environmental Area? If Yes, identify: _____	NO	YES	
	<input checked="" type="checkbox"/>	<input type="checkbox"/>	
8. a. Will the proposed action result in a substantial increase in traffic above present levels? b. Are public transportation services available at or near the site of the proposed action? c. Are any pedestrian accommodations or bicycle routes available on or near the site of the proposed action?	NO	YES	
	<input type="checkbox"/>	<input checked="" type="checkbox"/>	
	<input checked="" type="checkbox"/>	<input type="checkbox"/>	
	<input checked="" type="checkbox"/>	<input type="checkbox"/>	
9. Does the proposed action meet or exceed the state energy code requirements? If the proposed action will exceed requirements, describe design features and technologies: The proposed building(s) will meet or exceed the state energy code requirements. _____	NO	YES	
	<input type="checkbox"/>	<input checked="" type="checkbox"/>	
10. Will the proposed action connect to an existing public/private water supply? If No, describe method for providing potable water: _____	NO	YES	
	<input type="checkbox"/>	<input checked="" type="checkbox"/>	
11. Will the proposed action connect to existing wastewater utilities? If No, describe method for providing wastewater treatment: _____	NO	YES	
	<input type="checkbox"/>	<input checked="" type="checkbox"/>	
12. a. Does the project site contain, or is it substantially contiguous to, a building, archaeological site, or district which is listed on the National or State Register of Historic Places, or that has been determined by the Commissioner of the NYS Office of Parks, Recreation and Historic Preservation to be eligible for listing on the State Register of Historic Places? b. Is the project site, or any portion of it, located in or adjacent to an area designated as sensitive for archaeological sites on the NY State Historic Preservation Office (SHPO) archaeological site inventory?	NO	YES	
	<input checked="" type="checkbox"/>	<input type="checkbox"/>	
	<input type="checkbox"/>	<input checked="" type="checkbox"/>	
13. a. Does any portion of the site of the proposed action, or lands adjoining the proposed action, contain wetlands or other waterbodies regulated by a federal, state or local agency? b. Would the proposed action physically alter, or encroach into, any existing wetland or waterbody? If Yes, identify the wetland or waterbody and extent of alterations in square feet or acres: _____	NO	YES	
	<input type="checkbox"/>	<input checked="" type="checkbox"/>	
	<input checked="" type="checkbox"/>	<input type="checkbox"/>	

14. Identify the typical habitat types that occur on, or are likely to be found on the project site. Check all that apply:

- Shoreline
 Forest
 Agricultural/grasslands
 Early mid-successional
 Wetland
 Urban
 Suburban

15. Does the site of the proposed action contain any species of animal, or associated habitats, listed by the State or Federal government as threatened or endangered?

	NO	YES
<input checked="" type="checkbox"/>	<input type="checkbox"/>	<input type="checkbox"/>

16. Is the project site located in the 100-year flood plan?

	NO	YES
<input checked="" type="checkbox"/>	<input type="checkbox"/>	<input type="checkbox"/>

17. Will the proposed action create storm water discharge, either from point or non-point sources?
If Yes,

a. Will storm water discharges flow to adjacent properties?

b. Will storm water discharges be directed to established conveyance systems (runoff and storm drains)?

If Yes, briefly describe:

	NO	YES
<input type="checkbox"/>	<input checked="" type="checkbox"/>	<input checked="" type="checkbox"/>
<input type="checkbox"/>	<input checked="" type="checkbox"/>	<input checked="" type="checkbox"/>
<input type="checkbox"/>	<input checked="" type="checkbox"/>	<input checked="" type="checkbox"/>

Drainage will be collected and treated on site and will discharge to the existing on site stream, that flows north to the adjacent property.

18. Does the proposed action include construction or other activities that would result in the impoundment of water or other liquids (e.g., retention pond, waste lagoon, dam)?
If Yes, explain the purpose and size of the impoundment:

Proposed stormwater improvements and detention basin are anticipated but have not yet been designed at this time.

	NO	YES
<input type="checkbox"/>	<input checked="" type="checkbox"/>	<input checked="" type="checkbox"/>

19. Has the site of the proposed action or an adjoining property been the location of an active or closed solid waste management facility?
If Yes, describe:

	NO	YES
<input checked="" type="checkbox"/>	<input type="checkbox"/>	<input type="checkbox"/>

20. Has the site of the proposed action or an adjoining property been the subject of remediation (ongoing or completed) for hazardous waste?
If Yes, describe:

	NO	YES
<input checked="" type="checkbox"/>	<input type="checkbox"/>	<input type="checkbox"/>

I CERTIFY THAT THE INFORMATION PROVIDED ABOVE IS TRUE AND ACCURATE TO THE BEST OF MY KNOWLEDGE

Applicant/sponsor/name: Andrew B. Fetherston, P.E Date: 12/20/19

Signature: *Andrew B. Fetherston* Title: ENGINEER

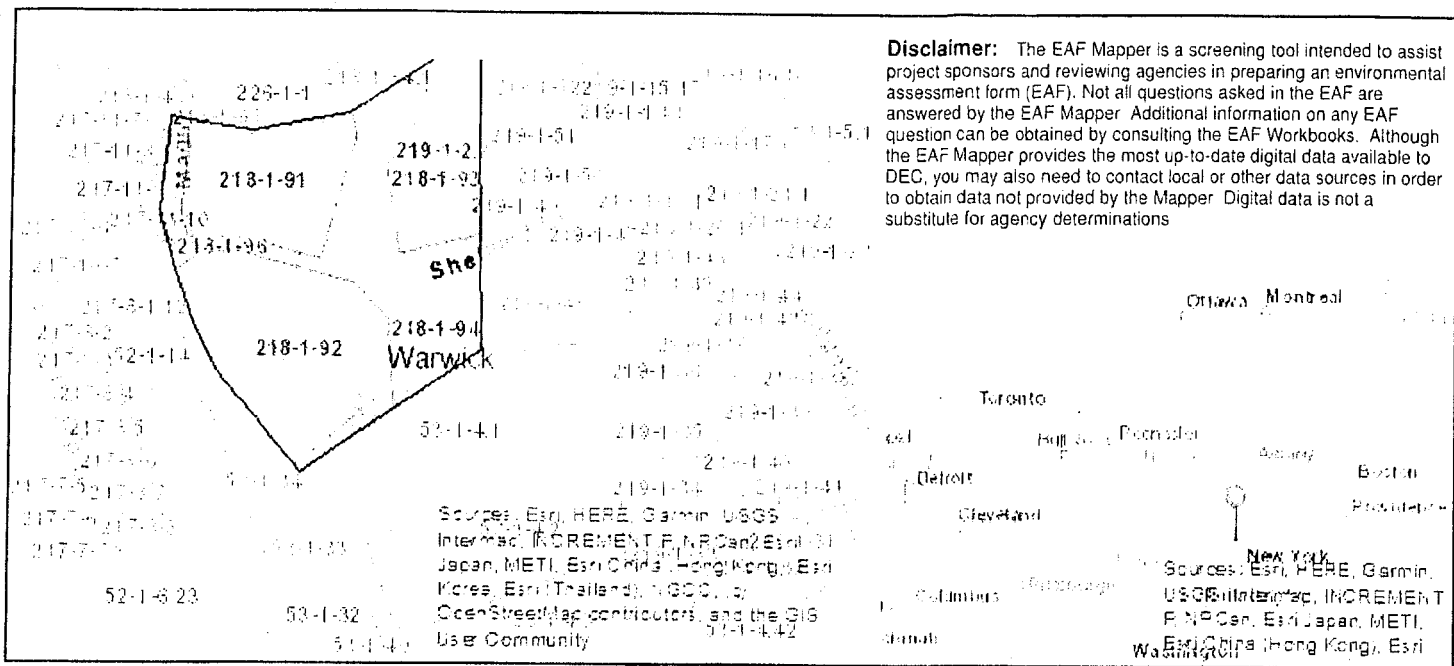

Disclaimer: The EAF Mapper is a screening tool intended to assist project sponsors and reviewing agencies in preparing an environmental assessment form (EAF). Not all questions asked in the EAF are answered by the EAF Mapper. Additional information on any EAF question can be obtained by consulting the EAF Workbooks. Although the EAF Mapper provides the most up-to-date digital data available to DEC, you may also need to contact local or other data sources in order to obtain data not provided by the Mapper. Digital data is not a substitute for agency determinations.

- Part 1 / Question 7 [Critical Environmental Area] No
- Part 1 / Question 12a [National or State Register of Historic Places or State Eligible Sites] No
- Part 1 / Question 12b [Archeological Sites] Yes
- Part 1 / Question 13a [Wetlands or Other Regulated Waterbodies] Yes - Digital mapping information on local and federal wetlands and waterbodies is known to be incomplete. Refer to EAF Workbook.
- Part 1 / Question 15 [Threatened or Endangered Animal] No
- Part 1 / Question 16 [100 Year Flood Plain] No
- Part 1 / Question 20 [Remediation Site] No

TAX MAP

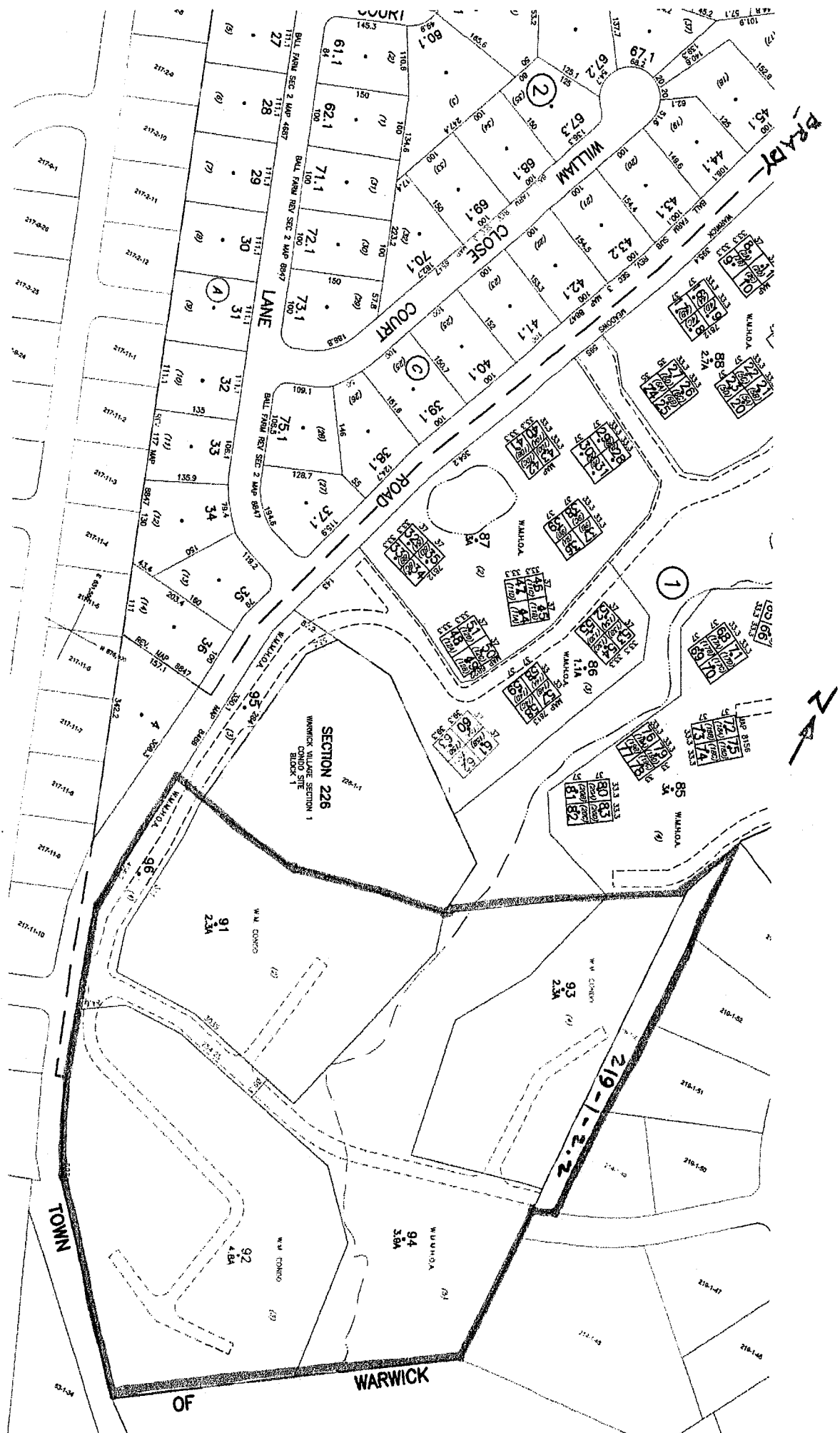

BRADY



TOWN

WARWICK

OF

219-1-2.2



94 Stewart Avenue, Newburgh, NY 12550
(845) 561 – 1512 | Fax: (845) 561 – 1204
Optimaenv.com

Optima's Essential and Emergency Services during COVID-19

To Our Valued Customers,

As we all grow to adapt to the COVID-19 landscape, the people at Optima Environmental Services want to remind you that we are working and will continue to provide our essential and emergency services throughout this difficult time. Our staff has been educated on Social Distancing and enhanced sanitization procedures and best practices, including an enhanced PPE protocol.

We are here for you. Should you require any immediate service to keep your operations running, Optima is standing by.

Optima's COVID-19 services include:

- Spill Response and Remediation
- Drum Disposal
- VAC Services
- All Service, Repair, and Maintenance
- Oil/Water Separator Clean-outs
- Fuel Tank Services including Tank Monitoring, Fuel Management and Dispensing equipment
- Fuel Tank Removals and Installations
- Petroleum Bulk Storage (PBS) Compliance
- Environmental Phase Assessments and Reports
- No Contact Pickup for orders from our Store, including customer hose and pipe fabrication
- COVID-19 Site Sanitization Maintenance

Please do not hesitate to contact our team if you need assistance during these changing times. We are all adjusting as the situation develops and want you to know Optima is here to help. We are available by phone, and the email address below is monitored 24/7. Please lean on us when you need our assistance.

(845) 561-1512
info@optimaenv.com

Special thanks to all of you who are working directly on the problem, and all those supporting the work of keeping our community safe. We'll get through this together.

Warmest Regards,

The People at Optima Environmental
Services

RECEIVED

APR 02 2020

Town of Warwick
Town Clerk

X

Warwick Town Clerk

From: Donna Lavins <dllavins@gmail.com>
Sent: Friday, March 27, 2020 4:19 PM
To: Michael Sweeton; Warwick Town Clerk
Cc: Donna Lavins
Subject: Re: MAJEWKI building a gymnasium too close to Points of View property. I understand it received a variance. But Points of View Association never received a notice.

Hi Michael and Eileen Astorino.

This is a correction on the name of the people responsible for building a gymnasium building that is too close to Points of View Association Property. See below.

Donna L. Lavins 
dllavins@gmail.com

RECEIVED
MAR 30 2020
Town of Warwick
Town Clerk

> On Mar 27, 2020, at 3:29 PM, Donna Lavins <dllavins@gmail.com> wrote:

- >
- > Hi Michael and everyone,
- > I hope that this note finds you and your families healthy and sane.
- >
- > I am writing to you because of a construction project that is in process, contracted by the Walkeski family on Waterbury Road. Evidently they are building a gymnasium that is 60 feet by 100 feet. The property that they are building on is adjacent to Points of View, more specifically it is adjacent to two properties 10 Points of View and 14 Points of View. I understand that the Fersko-Weiss family had attended the variance meeting, but even though they had reason to object to its proximity and even though they noted the property was zoned for 3 outbuildings and no more, the variance was given to the Waleski family.
- >
- > I understand that the Waleski's are good members of the community, but I believe that there must have been some misjudgment in allowing his variance. Please have someone contact me about this. This should never happened.
- >
- > I know you all don't need headaches, but, I think you should come out and look at what's happening here.
- >
- > With appreciation and respect for all you do.
- >
- >
- >
- > Donna L. Lavins
- > 26 Points of View
- > Warwick, NY 10990 
- > dllavins@gmail.com
- >
- >
- >
- >

RECEIVED

MAR 30 2020

Warwick Town Clerk

From: Winter, Neil L. Jr. <WINTERN@oru.com>
Sent: Friday, March 27, 2020 3:21 PM
To: Winter, Neil L. Jr.
Subject: ORANGE & ROCKLAND, ROCKLAND ELECTRIC CO. WARN CUSTOMERS: BEWARE SCAMMERS DURING CURRENT HEALTH EMERGENCY

Town of Warwick
Town Clerk

PEARL RIVER, NY March 27, 2020 2:30 p.m. – Orange & Rockland (O&R) and Rockland Electric Co. remind customers to remain aware of would-be scammers during the coronavirus emergency.

Scammers may take advantage of the emergency to try to get customers to give them money or to let them in their homes.

Orange & Rockland and Rockland Electric Co. offer this advice:

- Beware of anyone visiting, e-mailing, or calling about outstanding bills or disconnecting service. You are not going to lose your power now even if you can't pay your bill.
- If anyone asks for money for "new meters because of coronavirus," that's bogus. We don't charge for meters. And, we've put smart meter installation on hold.
- If someone comes to your door, verify they are who they say they are. We'll only enter your home or business for emergencies, safety reasons and upon your request for critical issues, including turning on service. If someone claims to be from Orange & Rockland or Rockland Electric Co., call 1-877-434-4100 to check the employee's name and ID#.
- If you are making a payment, do it safely. We never accept payment by cash apps such as Venmo, or bitcoin. We only accept online payments via www.oru.com/myaccount. or by downloading the free O&R mobile app.
- If you're suspicious about an e-mail from Orange & Rockland or Rockland Electric Co., don't click on any links you're unsure about.

Also, if you have an appointment with us, please let us know if you or anyone on your premises is quarantined by calling us. We're here to keep New York and New Jersey safe and your energy reliable.

To get the most recent information about help Orange & Rockland and Rockland Electric Co. are providing to our customers visit www.oru.com and click on the Coronavirus Update button under the Coronavirus panel on the homepage.

Orange and Rockland Utilities, Inc. (O&R), a wholly owned subsidiary of Consolidated Edison, Inc., one of the nation's largest investor-owned energy companies, is a regulated utility. O&R provides electric service to approximately 300,000 customers in southeastern New York State (where its franchise name is Orange & Rockland) and northern New Jersey (where it's Rockland Electric Company) and natural gas service to approximately 130,000 customers in New York.

Warwick Town Clerk

From: dos.sm.codes.1203ReportForm <dos.sm.codes.1203ReportForm@dos.ny.gov>
Sent: Saturday, March 28, 2020 9:50 AM
To: Town of Warwick Building Department
Cc: Michael Sweeton; Warwick Town Clerk
Subject: RECEIPT: Annual Report of Code Enforcement Activities for Town of Warwick
Attachments: 1203_annual_report_2019.pdf; 1203_annual_report_personnel.pdf

Dear Daniel Gibson,

This email confirms your electronic submission of the *Uniform Code and Energy Code Administration and Enforcement Report (Reporting Year 2019)* for Warwick on 3/17/2020 3:48:24 PM. A copy of your submission is attached for your records. This is the first submission received for the reporting year. A report on training status of employees you listed in your submission is also attached. Please review both attachments and promptly advise if you note any omissions, inaccuracies, or other irregularities in either of the attachments.

If you have any questions, please contact the Division office by replying to this email or using contact information provided below.

Oversight Unit

Division of Building Standards and Codes
New York Department of State
 99 Washington Avenue, Suite 1160
 Albany, NY 12231
 (518) 474-4073
www.dos.ny.gov

RECEIVED

MAR 30 2020

Town of Warwick
Town Clerk

You are receiving this message because you have been identified as the official who most recently submitted a report on behalf of Warwick or because you are identified in records provided to our agency by the Office of State Comptroller as the chief executive or municipal clerk for Warwick or the local government which is responsible for enforcement of the Uniform Code or Energy Code in Warwick.



**Building Standards
and Codes**



By April 1, 2020, your home should receive an invitation to participate in the Census. Please respond: online, by phone or by mail.

<https://2020census.gov/en/ways-to-respond.html>



Building Standards and Codes

One Commerce Plaza
99 Washington Ave, Suite 1160
Albany, NY 12231-0001
(518) 474-4073
Fax. (518) 474-5788
<https://www.dos.ny.gov/dcea>

UNIFORM CODE ADMINISTRATION AND ENFORCEMENT REPORT (REPORTING YEAR: 2019)

Instructions		
<p>The official who oversees code enforcement activities for your city, town, village, or county jurisdiction must complete this form. If your local government has transferred such responsibilities to another local government by opting out of enforcement or entering a shared services agreement as provided by law, then this official will be part of the other local government. Even if your local government is not required to submit the report because it has transferred responsibility, we recommend you complete this form to assure the Department of State has accurate information about who is responsible for code enforcement in your jurisdiction.</p> <p>The "Reporting Year" is the calendar year (January through December) for which the reported data have been collected. The "Uniform Code" is the New York State Uniform Fire Prevention and Building Code. The "Energy Code" is the New York State Energy Conservation Construction Code. The "Code Official" is the official enforcing the Uniform Code or Energy Code in the $\{(muni_type)\}$.</p> <p>If you are submitting on behalf of a local government that administers the Uniform Code or the Energy Code for other local governments, you must submit a separate report on each city, town, village, and county for which you administer those services.</p> <p>If you still have questions after reviewing this form and instructions, please contact the Division of Building Standards and Codes at (518) 474-4073.</p>		
Name of Municipality		
Town of Warwick (330387300000)		
Address	City	Zip Code
132 Kings Highway	Warwick	10990
Responsibility for Enforcement of the Uniform Code and the Energy Code		
Did the local government adopt a local law providing it will *not* enforce the Uniform Code and Energy Code that was in effect during the reporting period?		No
Has the local government entered into an agreement pursuant to General Municipal Law, Article 5-G, with one or more other local governments to jointly administer the Uniform Code or Energy Code as authorized by Executive Law Section 381(2)?		No
If yes and a different local government is responsible for administration of Uniform Code, specify:		
If yes and a different local government is responsible for administration of Energy Code, specify:		
Does the local government employ any code enforcement officials or building safety instructors to support its administration of the Uniform Code or Energy Code?		Yes
Submitting Official and Reporting Period		
Local government which employs submitter		Warwick
Name of Person Submitting Report		
Daniel Gibson		
Phone	Email	
8459861127	building@townofwarwick.org	
Title and Department	Reporting Period	
	Jan 1, 2019 - Dec 31, 2019	

**UNIFORM CODE ADMINISTRATION AND ENFORCEMENT REPORT
(REPORTING YEAR: 2019)**

Assignment of Responsibilities by Submitting Local Government

Are third-party contracted services used to meet the requirements of 19 NYCRR Part 1203? **No**

Does the third-party meet the education requirements of 1203.2(e)(1)?

Does the fire department perform fire safety inspections? **No** If "No", who is responsible for fire safety inspections? **Building Department**

No **Building Department**

Legislative Authorization

Please list the local law, ordinance or other appropriate regulation that provides for the administration and enforcement of the NYS Uniform Fire Prevention and Building Code and Energy Conservation Construction Code in this municipality:

Local Law Chapter #82

Local Legislative Modifications of Uniform Code Standards

Does the submitting local government have in effect any local law or ordinance that imposes construction standards that are different from the requirements imposed by the Uniform Code? **No**

Is each such local law or ordinance approved or pending approval by the State Fire Prevention and Building Code Council pursuant to Executive Law Article 18, Section 379?

Specify the year and number of the local law(s) or ordinance(s):

Local Legislative Modifications of Energy Code Standards

Does the submitting local government have in effect any local law or ordinance that imposes energy conservation standards that are different from the requirements imposed by the *Energy Code*? **No**

Is each such local law or ordinance filed with State Fire Prevention and Building Code Council pursuant to Energy Law § 11-109?

Specify the year and number of the local law(s) or ordinance(s):

Building Permits

Write the number of building permits issued for each occupancy type listed.

	New construction	Addition, alteration, or repair of existing
One-family dwellings, two-family dwellings, and townhouses	43	157
Other residential occupancies	0	0
Nonresidential buildings	3	7
All other permits (pools, sheds, decks, plumbing, HVAC, etc.)	770	1010
	Certificates of Occupancy or Compliance issued for all occupancies	

Stop Work Orders

Number of Stop Work Orders issued in reporting year?

26

Notification of Fire or Explosion

Have procedures been established for notification by the chief of your fire department(s) regarding fire or explosion involving any structural damage, fuel burning appliance, chimney, or gas vent?

No

Unsafe Structures and Equipment

Have procedures been established for identifying and addressing unsafe structures and equipment?

Yes

**UNIFORM CODE ADMINISTRATION AND ENFORCEMENT REPORT
(REPORTING YEAR: 2019)**

Operating Permits

Are operating permits required by the municipality?	No
Manufacturing, storing, or handling hazardous materials in quantities exceeding those listed in Tables 5003.1.1(1-4) of the Fire Code of New York State (see 19 NYCRR Part 1225):	
Hazardous processes and activities, including but not limited to commercial and industrial operations which produce Combustible dust as a byproduct, fruit and crop ripening, and waste handling:	
Use of pyrotechnic devices in assembly occupancies:	
Buildings containing one or more areas of public assembly with an occupant load of 100 or more persons:	
Buildings whose use or occupancy classification may pose a substantial potential hazard to public safety, as determined by the government or agency charged with or accountable for administration and enforcement of the Uniform Code:	
Parking garages:	

Other Operating Permits

Describe operating permit category	Number of permits issued

Special Inspections (as defined in Section 1702 of the Uniform Code)

Does the local government require special inspections?	No
Does the local government retain special inspection reports?	
Does the municipality require a statement of special inspections required as part of a condition for permit issuance?	
Does the municipality require special inspection reports to be submitted prior to issuance of certificates of compliance or completion?	

Practices

Please identify all procedures used by the municipality to ensure compliance with the Uniform Code:
field_inspections,plan_reviews,software_report,compliance_checklist

Please identify all procedures used by the municipality to ensure compliance with the Energy Code:
field_inspections,plan_reviews,software_report,compliance_checklist

Record Keeping

Has a system of records of the features and activities specified in 19 NYCRR 1203.3(a-j) been established and maintained?
Yes

UNIFORM CODE ADMINISTRATION AND ENFORCEMENT REPORT (REPORTING YEAR: 2019)

On average, how many site inspections are conducted for Uniform Code compliance for each new residential building?				10	
On average, how many site inspections are conducted for Uniform Code compliance for each new commercial building?					
On average, how many site inspections are conducted for Energy Code compliance for each new residential building?				1	
On average, how many site inspections are conducted for Energy Code compliance for each new commercial building?					
Buildings Containing One Or More Areas of Public Assembly (area with occupant load of 50 or greater)					
Number of buildings	20	Number inspected	15	Not inspected in last 12 months	5
Buildings Containing 3 or More Dwelling Units					
Number of buildings	5	Number inspected	4	Not inspected in last 36 months	0
Number of dwelling units in such buildings				21	
Dormitories					
Number of buildings	0	Number inspected	0	Not inspected in last 36 months	0
Nonresidential Buildings					
Number of buildings	0	Number inspected	0	Not inspected in last 36 months	0

Are any of the numbers reported in this section estimates?	No
Please describe briefly which figures are estimated and how estimates were calculated.	

UNIFORM CODE ADMINISTRATION AND ENFORCEMENT REPORT (REPORTING YEAR: 2019)

Energy Code

The State Energy Conservation Construction Code (Energy Code) was amended and updated in its entirety, effective October 3, 2016. The amended and updated version of the Energy Code includes specific requirements relating to construction documents, applications for building approvals of applications for building permits, and inspections and tests to be performed during construction. The questions in this section of this Report relate to the Municipality's familiarity with, and ability to enforce, these new provisions.

In this section of this Report, the term "2015 IECC" means the 2015 edition of the International Energy Conservation Code (Second Printing, May 2015), the term "2016 Energy Code Supplement" means the publication entitled "2016 Supplement to the New York State Energy Conservation Construction Code (Revised August 2016)," the term "residential building" is as defined in the 2016 Energy Code Supplement, and the term "commercial building" means any building that is not a residential building

The term "residential building" includes: (1) detached one-family dwellings having not more than three stories above grade plane; (2) detached two-family dwellings having not more than three stories above grade plane; (3) buildings that (i) consist of three or more attached townhouse units and (ii) have not more than three stories above grade plane; (4) buildings that (i) are classified in accordance with Chapter 3 of the 2015 International Building Code (as amended) in Group R-2, R-3 or R-4 and (ii) have not more than three stories above grade plane; (5) factory manufactured homes (as defined in section 372(8) of the New York State Executive Law); and (6) mobile homes (as defined in section 372(13) of the New York State Executive Law). For the purposes of this definition of the term "residential building," the term "townhouse unit" means a single-family dwelling unit constructed in a group of three or more attached units in which each unit (i) extends from the foundation to roof and (ii) has open space on at least two sides.

Does the Municipality require that construction documents submitted as part of an application for a building permit? show the following data and features of the building in sufficient detail to allow the Municipality to determine whether the building does or does not comply with the Energy Code:

Representation of building's thermal envelope?

Yes

Insulation materials and their R-values?

Yes

Fenestration U-factor and solar heat gain coefficient (SHGC)?

Yes

Area-weighted U-factor calculations and SHGC values (where applicable)?

Yes

Mechanical system design criteria (Manual "J" and Manual "S" for residential buildings)?

Yes

Mechanical and service water heating system and equipment types, sizes, and efficiencies?

Yes

Economizer description (in the case of a commercial building)?

Yes

Equipment and system controls (in the case of a commercial building)?

Yes

Fan motor horsepower (hp) and controls (in the case of a commercial building)?

Yes

Duct sealing, duct and pipe insulation and location?

Yes

Lighting Fixture schedule with wattage and control narrative (in the case of a commercial building)?

No

Location of daylight zones on floor plans (in the case of a commercial building)?

No

Air sealing details?

Yes

**UNIFORM CODE ADMINISTRATION AND ENFORCEMENT REPORT
(REPORTING YEAR: 2019)**

When the Municipality determines the construction documents to be in compliance with the applicable requirements of the Energy Code and accept the documents, does the Municipality stamp the construction documents "Reviewed for Energy Code Compliance" and endorse the documents in writing?

Yes

Where the construction documents are required to be prepared by a New York State registered architect or licensed professional engineer, does the Municipality require that the documents bear the seal or stamp and signature of such registered architect or licensed professional engineer and include, immediately above the signature, a statement substantially similar to the following: "To the best of the knowledge, belief, and professional judgment of the undersigned [registered architect or licensed professional engineer], the plans and specifications depicted on these drawings are in compliance with the applicable provisions of the New York State Uniform Fire Prevention and Building Code and the New York State Energy Conservation Construction Code, as currently in effect."?

Yes

Are inspections completed for each of the following (where applicable):

Inspections of footings and foundations to verify compliance with the Energy Code as to R-value, location, thickness, depth of burial and protection of insulation as required by the Energy Code and approved plans and specifications?

Yes

Inspections at framing and rough-in, made before application of interior finish and to verify compliance with the Energy Code as to types of insulation and corresponding R-values and their correct location and proper installation, fenestration properties (U-factor and SHGC and, in the case of a commercial building, VT), and proper installation and air leakage components as required by the Energy Code and approved plans and specifications?

Yes

Inspections at plumbing rough-in to verify compliance as required by the Energy Code and approved plans and specifications as to types of insulation and corresponding R-values and protection, required controls, and required heat traps on potable water heaters?

Yes

Inspections at mechanical rough-in to verify compliance as required by the Energy Code and approved plans and specifications as to installed HVAC equipment type and size, required controls, system insulation, and corresponding R-value; system and damper air leakage (in the case of a commercial building) or system air leakage control (in the case of a residential building); and required energy recovery and economizers (in the case of a commercial building) or programmable thermostats, dampers, whole-house ventilation, and minimum fan efficiency (in the case of a residential building)?

Yes

Inspections at electrical rough-in to verify compliance as required by the Energy Code and approved plans and specifications as to installed lighting systems, components and controls and, if applicable, installation of an electric meter for each dwelling unit?

Yes

A final inspection that verifies, in the case of a commercial building, the installation and proper operation of all building controls required by the Energy Code, the receipt of documentation verifying that activities associated with building commissioning required by the Energy Code have been conducted and that findings of noncompliance corrected, and the receipt of the HVAC system certification required by the Energy Code; and the final inspection shall verify, in the case of a residential building, the installation of all building systems, equipment, and controls required by the Energy Code and their proper operation and the installation of the number of high-efficacy lamps and fixtures required by the Energy Code?

Yes

In the case of residential buildings:

Does the Municipality require that a permanent certificate listing the predominant R-values of insulation installed be completed by the builder or registered design professional and posted on a wall in the space where the furnace is located?

Yes

Does the Municipality require that building envelope values be confirmed as code compliant by at least one of the following methods? Prescriptive, Trade-off method (RESCheck), Energy Rating Index (2015 IECC Section R406)

Yes

In case of detached one-and-two family dwellings, townhouses, and multiple family dwellings of three stories or less, does the local government require that an air leakage test (blower door test) be performed on the completed building envelope?

Yes

UNIFORM CODE ADMINISTRATION AND ENFORCEMENT REPORT (REPORTING YEAR: 2019)

Does the local government require verification that the air leakage rate is 3 ACH (50 pascals) or less?

Yes

Does the Municipality require that written report of the results of the ACH 50 test be signed by the party conducting the test and provided to the Municipality?

Yes

In a case where any part of the HVAC duct system located outside of the building envelope, does the Municipality require that a duct tightness test be performed?

Yes

Does the code official receive a written report of the results of the test signed by the party conducting the test?

Yes

In the case of commercial buildings:

Does the Municipality require the demonstration of compliance with one of the following compliance paths?

ASHRAE Compliance Path: Compliance with the requirements of ASHRAE 90.1-2013, as amended by the 2016 Energy Code Supplement.

Prescriptive Compliance Path: Compliance with the requirements of (1) Sections C402 through C405 of the 2015 IECC, as amended by the 2016 Energy Code Supplement, (2) Section C406 of the 2015 IECC, as amended by the 2016 Energy Code Supplement, and (3) in the case of tenant spaces, Section C406.1.1 of the 2015 IECC, as amended by the 2016 Energy Code Supplement.

Performance Compliance Path: Compliance with the requirements of Sections C402.5, C403.2, C404, C405.2, C405.3, C405.5, C405.6, and C407 of the 2015 IECC, as amended by the 2016 Energy Code Supplement, with building energy cost to be equal to or less than 85 percent of the standard reference design building.

Yes

Does the Municipality require construction documents to clearly indicate provisions for commissioning and completion requirements in accordance with Section C408 of the 2015 IECC?

Yes

Project Compliance

For each of the following project categories, provide the total number of projects in each category that were completed during the year covered by this report and the number of such completed projects that comply with the applicable requirements of the Energy Code:

New commercial building construction projects completed	0	Completed new commercial building construction projects that are compliant	0
New residential building construction projects completed	43	Completed new residential building construction projects that are compliant	43
Existing commercial building construction projects completed	0	Completed existing commercial building construction projects that are compliant	0
Existing residential building construction projects completed	26	Completed existing residential building construction projects that are compliant	26

With respect to the response to previous question, provide a description of the methods used to verify such compliance with the Energy Code.

On site inspections.RES Check

**UNIFORM CODE ADMINISTRATION AND ENFORCEMENT REPORT
(REPORTING YEAR: 2019)**

Complaints

Total number of all registered Uniform Code related complaints received for reporting year	158	Total number of all registered Uniform Code related complaints received for reporting year	158
Total number of all registered Energy Code related complaints received for reporting year	0	Total number of all registered Energy Code related complaints acted upon for reporting year	0

Are any of the numbers reported in this section estimates?
(Answer 'Yes' if any of the numbers of occupancies or inspections reported were estimated rather than tabulated from electronic records or manual counting of records.)

No

Please describe briefly which figures are estimated and how estimates were calculated.

Additional Information

Please provide any additional information or comments
(Provide any additional information or comments that may prove helpful in processing the form and interpreting your response. Provide feedback on any data that were difficult to obtain and any concerns that might influence the accuracy, completeness, or precision of information you provided.)

Complete your submission

If you are using Google Chrome to submit, you may now print your application. Please click the PRINT button (image of a printer) on the upper right of this screen before you hit submit. This will allow you to print your completed form or save it to a PDF file if your computer supports that. You will not be able to retrieve the form once you submit it. Acknowledge that you have considered printing your form before you submit.

OK

Personnel Reported by the Town of Warwick for 2019

Name	Role	Ctrct	Email (if provided)	CEO/BSI Cert.	Hr/W	Active?	Training Requirements Fulfillment	2018	2019	2020
------	------	-------	---------------------	---------------	------	---------	-----------------------------------	------	------	------

Daniel Gibson bsi dpg0429@optonline.net 32.5 No

NOTE: This information is based on the records processed to date by the Educational Services Unit within the Division of Building Standards and Codes and matched to the certification or training identification numbers of code officials provided by the local government in its annual report.

Discrepancies in your training history should be directed to the Educational Services Unit within the Division of Building Standards and Codes by email to: doscodestraining@dos.ny.gov

Professional Development Elective forms should be submitted to the Educational Services Unit within the Division of Building Standards and Codes by email to: doscodestraining@dos.ny.gov

X

Warwick Town Clerk

From: Scali, Carrie <CScali@orangecountygov.com>
Sent: Monday, March 30, 2020 12:13 PM
To: Scali, Carrie
Subject: GML 239 Update

RECEIVED
MAR 30 2020
Town of Warwick
Town Clerk

Hello

As a result of the Coronavirus (COVID-19) pandemic, the Orange County Planning Department is carefully reviewing the departments' priorities and planning to continue to provide critical and essential services while ensuring the health, safety and welfare of our employees. This includes mandatory NYS GML 239 referrals for subdivisions, site plans, special use permits, area variances, use variances, or local laws (zone changes and comprehensive plan amendments) be sent to the OC Department of Planning (OCDP) by municipalities.

At this time, we will continue to process NYS GML 239 reviews that are referred. However, some staff are working remotely and require digital submissions to complete reviews. Please assist us in this effort by providing **both** a digital copy of the site plan, county referral form and other supporting documents to our Department email (planning@orangecountygov.com), as well as a hard copy mailed to 124 Main Street, Goshen, NY. OCDP staff will access the referrals via email and send a review letter response within 30-days of obtaining a full statement of the proposed action. A Full Statement of a Proposed Action is defined as "all materials required by and submitted to a referring body (Town or Village Board, City Council, Planning Board or Zoning Board of Appeals) as an application on a proposed action."

Thank you for your understanding.

Stay Healthy,

Carrie

Carrie Scali
Planning Assistant
Orange County Planning Department
124 Main Street
Goshen, NY 10924

This communication may contain confidential information and is intended only for the individual or entity to whom it is addressed. Any review, dissemination, or copying of this communication by anyone other than the intended recipient is strictly prohibited. If you are not the intended recipient, please contact the sender, and destroy all copies of the original message. No responsibility is accepted by Orange County Government for any loss or damage arising in any way from receiving this communication.

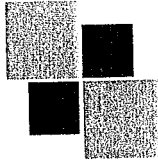

LEHMAN & GETZ
CONSULTING ENGINEERS

cc
T/Clerk ✓
T/TBD ✓
Ben A. ✓

March 23, 2020

Supervisor Michael Sweeton
Town of Warwick Town Board
132 Kings Highway
Warwick, NY 10990

RECEIVED

MAR 27 2020

Town of Warwick
Town Clerk

Re: Wise Equities LLC Property
Knights Lane
Wickham Lake Estates Subdivision
L&G #2421

Dear Supervisor Sweeton and Town Board Members:

We request your approval of a modification of the required road width for the proposed road construction of Knights Lane, a road that was approved as part of the Wickham Lake Estates Subdivision. Wise Equities LLC has purchased a portion of the subdivision, and plans to build the road and five new residences.

A paved road width of thirty feet is shown on the approved subdivision plans. We request approval of a reduced width of twenty-four feet. We feel that the reduced width is consistent with the limited number of lots along the road and with the Town's goals to reduce runoff, maintenance costs, and ground disturbance. I have discussed the situation with Ben Astorino and Laura Barca, and they indicated that they are supportive of the revision.

Thank you for your consideration.

Sincerely,

Lehman & Getz, P.C.
David A. Getz, P.E.

cc: David Ungar
Wise Equities, LLC
Ben Astorino
Laura Barca, P.E.

RECEIVED
MAR 27 2020
TOWN OF WARWICK
SUPERVISOR'S OFFICE

X

Warwick Town Clerk

From: Sandy Bourne <sbourne@mercatus.gmu.edu>
Sent: Friday, March 27, 2020 11:40 AM
To: Warwick Town Clerk
Subject: COVID-19 Pandemic Policy Response: Public-Private Virtual School Partnerships and Federal Flexibility for Schools

Dear Ms. Astorino,

In response to the ongoing Coronavirus public health and economic crisis, Mercatus is publishing timely, short-essays to address pressing policy questions affecting Congress, state and local governments, and the American economy.

As more states make the decision to cease classroom learning for the remainder of the school year, the potential of moving 41 million students online will be no easy task. Today, an essay by Jonathan Butcher titled, "Public-Private Virtual School Partnerships and Federal Flexibility for Schools During the Coronavirus," argues that policymakers should look to existing state charter school laws for examples of ways to offer flexibility to traditional school districts. In addition, schools should create public-private partnerships with existing virtual providers to serve student learning.

The main benefits to these policy changes include:

- Decisive and quick action by policymakers and educators will prevent students from falling behind before the next school year.
- These changes allow teachers and parents to see what the future of learning could be for millions of students.

Should you have any questions or would like to learn more about this timely report, please do not hesitate to contact us.

Sincerely,

Sandy Liddy Bourne
Mercatus Center at George Mason University
Director of State Outreach
3434 Washington Boulevard
4th Floor
Arlington, Virginia 22201

RECEIVED
MAR 30 2020
Town of Warwick
Town Clerk

sbourne@mercatus.gmu.edu
703-993-8148

[Unsubscribe](#)



X

Warwick Town Clerk

RECEIVED

From: Winter, Neil L. Jr. <WINTERN@oru.com>
Sent: Wednesday, April 08, 2020 8:46 AM
To: Winter, Neil L. Jr.
Subject: Please Alert O&R of Emergency Work During the Pandemic Crisis

APR 08 2020
Town of Warwick
Town Clerk

During a public health emergency, safe excavation around O&R natural gas and electric facilities is more important than ever before, as damages often mean sending first responders into homes. This creates a possible health risk from the coronavirus both for the homes' residents, and for police and fire personnel, and O&R emergency responders. We are asking that you help prevent this unnecessary risk, by taking the necessary precautions to avoid a gas or electric damage.

As your utility company, O&R's primary goal is to safely maintain our gas and electric infrastructure. I'm writing to ask for your cooperation in helping us increase the safety and integrity of those systems during the current public health emergency. Gov. Andrew Cuomo's Executive Order 202.6 last week defined the services deemed "essential" to the community during the health crisis. While O&R continues to work, our gas & electric groups are limited to only essential work.

Emergent Municipal Projects

If any emergency construction repair projects unexpectedly develops (emergency water or sewer repairs, for example), immediately alert O&R Gas Engineering (Al Gaddi, gaddia@oru.com or 845-554-4986). Once, O&R is notified, the utility will review the proposed emergency work's limits to determine if our facilities could be impacted and if necessary, dispatch appropriate oversight personnel to the site to prevent damage to our facilities.

Call 811 Before You Dig

Please continue to follow 811 requirements by appropriately calling 811 before you excavate. Once notified by 811, O&R will send a technician to the location to mark and identify utility-owned lines with stakes, flags or paint to clearly mark areas to avoid. It's simple, fast, free, and it's the law.

Reporting Damages

If a natural gas accident occurs or a digging accident occurs, **immediately evacuate the area and call** O&R's Gas Emergency Hotline (800-533-5325), 911, or your local gas provider. For accidents or damages involving overhead or underground electric cables, call O&R at 877-434-4100.

MAR 23 2020

Warwick Town ClerkTown of Warwick
Town Clerk

From: Winter, Neil L. Jr. <WINTERN@oru.com>
Sent: Monday, March 23, 2020 1:40 PM
To: Winter, Neil L. Jr.
Subject: O&R, Rockland Electric Co. Expand Efforts to Protect Public During Coronavirus Emergency - Focus Is On Maintaining Safe, Reliable Service

PEARL RIVER, NY March 23, 2020 – In their continuing effort to protect customers and employees from the coronavirus (COVID-19), Orange & Rockland (O&R) and Rockland Electric Co. have halted all meter reading and installation of smart meters at customers' homes.

The decision builds on steps the companies took previously to support public health and safety.

Orange & Rockland and Rockland Electric Co. are always ready to respond to every emergency. The energy companies managers and crews are committed to keeping New York and New Jersey safe and the service reliable.

"Nothing is more important than health and safety," said Robert Sanchez, the president and CEO of Orange & Rockland and Rockland Electric Co. "We want to protect everyone while providing the safe, reliable service our customers need. While many of our in-home work activities have been put on hold, we are focusing on system infrastructure work that ensures safety and reliability."

Orange & Rockland and Rockland Electric Co. will enter a customer's home only for emergencies, safety-related inspections and customer-requested service connections and enhancements.

Orange & Rockland and Rockland Electric Co. employees who need to enter a home for one of these reasons will carry proper identification. Our workers are following U.S. Centers for Disease Control (CDC) and New York State and New Jersey guidelines.

The workers will ask if anyone in the household is ill and discuss how they may carry out their tasks with everyone's safety and comfort in mind. If you have an appointment with us, please let us know if you or anyone in your premises is quarantined by calling 1-877-434-4100. All company employees and contractors are advised to follow social distancing guidelines.

Other steps O&R and Rockland Electric Co. have taken include:

- Stopping shutoffs of electric and natural gas service due to non-payment resulting from the health crisis. We will continue to shut off service when there is a safety issue.
- Will not bill new late-payment charges for all customers and will suspend the fee charged to a customer who is unable to grant access to their property.
- Temporarily shutting down customer service walk-in business centers. Customers still can do business with Orange & Rockland and Rockland Electric Co. online via www.oru.com/myaccount. or by downloading the free O&R mobile app.

Orange & Rockland and Rockland Electric Co. also are having administrative employees work from home, field personnel conduct pre-job briefings in smaller groups, and dividing workers into teams. The company instructs employees to follow the CDC guidelines, including hand washing, and social distancing.

Orange and Rockland Utilities, Inc. (O&R) is a wholly owned subsidiary of Consolidated Edison, Inc., one of the nation's largest investor-owned energy companies. O&R is a regulated utility that provides electric service to approximately 300,000 customers in southeastern New York State (where its franchise name is Orange & Rockland) and northern New Jersey (where it's Rockland Electric Company), and natural gas service to approximately 130,000 customers in New York.

CONNECT WITH US:



###

X

Warwick Town Clerk

From: Greenwood Lake Commission <1616gwlc@gmail.com>
Sent: Saturday, March 21, 2020 5:44 PM
Subject: Greenwood Lake Commission's March 25, 2020 meeting has been postponed until Wednesday April 1, 2020

To conform with the state mandated regulations and to do our part to promote social distancing and self-quarantine in our community; The Greenwood Lake Commission's March 25, 2020 meeting has been postponed until **Wednesday April 1, 2020** and will be a Teleconference call via Zoom. Please be advised, there is registration required to attend the meeting. If there are any documents you wish to share with the Commission for the meeting, please contact us and make arrangements to drop them off at the office located at 2019 H Greenwood Lake Turnpike, Hewitt, NJ. The physical location of the meeting will be at the office for Commissioners only to attend. There will be future communications with all the information needed to join our meeting.

Stay Safe and Be Well,

The Greenwood Lake Commission

www.gwlc.org info@gwlc.org

973-506-7800

Kind Regards,

Allison Wagner
Greenwood Lake Commission
P.O. Box 93
Hewitt, NJ 07421
973-506-7800

RECEIVED
MAR 23 2020
Town of Warwick
Town Clerk

X

RECEIVED

Warwick Town Clerk

MAR 23 2020

From: Sandy Bourne <sbourne@mercatus.gmu.edu>
Sent: Saturday, March 21, 2020 10:15 AM
To: Warwick Town Clerk
Subject: Covid-19 Pandemic Policy Response: Temporary Lending Reforms

Warwick
Town Clerk

Dear Ms. Astorino,

In response to the ongoing Coronavirus public health and economic crisis, Mercatus is publishing timely, short essays to address pressing policy questions affecting Congress, state and local governments, and the American economy.

Policymakers and the public have called for bold actions to limit the contraction of markets and provide direct assistance to struggling American families. One concern of direct cash payments is that they can be costly to taxpayers and difficult to quickly distribute to those with the greatest need. Today, Mercatus published an essay by Kevin Erdmann, titled "**Get Cash to More Families That Need It Now.**" Erdmann argues that financial intuitions should be given more discretion in providing customers home equity loans and mortgage refinancing.

Erdmann's commentary was also published in Politico this morning: **How Mortgages Can Ease the Downturn.**

The main benefits to these policy changes:

- Approximately 81 million homeowners would have access to nearly \$19 trillion in home equity on properties valued at nearly \$30 trillion.
- It creates a temporary avenue for secured bank lending and providing a way for American families to decide for themselves who needs short-term cash, and to accept responsibility for repayment when the economy stabilizes.

Please **regularly check our website** for all of the Mercatus Center's up-to-date research and responses to the COVID-19 pandemic.

Should you have any questions or would like to learn more about this **timely report**, please do not hesitate to contact us.

Sincerely,

Sandy Liddy Bourne
 Mercatus Center at George Mason University
 Director of State Outreach
 3434 Washington Boulevard
 4th Floor
 Arlington, Virginia 22201

sbourne@mercatus.gmu.edu
 703-993-8148

[Unsubscribe](#)

X

Warwick Town Clerk

From: Tyler Wren <tyler@wrenegadesports.com>
Sent: Monday, March 23, 2020 11:05 AM
To: Warwick Town Clerk
Subject: Date change for Farm to Fork Fondo event

RECEIVED

MAR 23 2020

Town of Warwick
Town Clerk

Hello Eileen,

I hope you and everyone in Warwick are staying safe and healthy during this time.

I am writing to inform you that we have changed the date of Farm to Fork Fondo at Bellvale Farms to Sept 20, 2020. Can you amend our permit application, or would you like us to submit another? My colleague Andrew is on leave, so I can amend the permit that he submitted if needed. Please advise.

Thank you,

Tyler

--



FARM TO FORK

fitness adventures



Tyler Wren | Founder & Principal | 610-574-1334 | tyler@wrenegadesports.com

2020 Farm to Fork Fitness Adventure Schedule



production of
WRENEGADE
sports

ll

Faint, illegible text at the bottom of the page, possibly a footer or additional contact information.

X

Warwick Town Clerk

From: Siljkovic,Ermin <ESiljkovic@orangecountygov.com>
Sent: Wednesday, April 01, 2020 9:33 AM
Subject: HHW Events Cancelled: Friday, April 10 CESQG Event and Saturday April 11 at Thomas Bull Memorial Park

Importance: High

To Whom It May Concern;

The hazardous waste collection events scheduled on Friday, April 10 for businesses, school districts, and farms and Saturday April 11 for residents have been cancelled. We will keep you informed if a make up date is to be scheduled.

Please stay tuned to <http://www.orangecountygov.com/efs> or call the telephone numbers below for any information.

In the meantime, please stay safe and healthy.

Sincerely,

Ermin Siljkovic
Recycling Coordinator
Orange County DPW
Division of Environmental
Facilities & Services (EF&S).
2455-2459 Route 17M, P.O. Box 637
Goshen, NY 10924
(845) 291-3246 (Office)
(845) 637-9041 (Cell)
(845) 291-4570 (Fax)
esiljkovic@orangecountygov.com

RECEIVED
APR 01 2020
Town of Warwick
Town Clerk

From: Siljkovic,Ermin
Sent: Thursday, March 05, 2020 2:06 PM
Subject: First CESQG Event of 2020 at Thomas Bull Memorial Park on April 10 (plus flyer for event for residents on April 11)

To Whom It May Concern;

We are pleased to announce the first of four hazardous material collection events for Conditionally Exempt Small Quantity Generators (CESQGs) where you as businesses, municipalities, school districts, and farms would qualify. This event will take place at **Thomas Bull Memorial Park** Picnic Area parking lot located on 90 Grove Street in the Town of Hamptonburgh on **Friday, April 10th**.

All participants ***MUST*** pre-register by **NO LATER THAN C.O.B. FRIDAY, MARCH 27**. If you have acceptable materials (see attached form), please complete the attached form, articulating the **QUANTITY** of each material you plan on bringing- specifically the number & volume of each container - on the first page, as well as the **AGGREGATE WEIGHT** of said materials on the second page. **NOTE:** Unsigned registrations and registrations containing over 220 lbs. of materials will be rejected.

Your registrations will be sent to our vendor, Care Environmental, who will then provide a quote based on your submission by the week before the event, providing you time to process purchase orders or checks. Your adherence to

registration procedures keep your costs down and help make this event possible. We are looking forward to working with you to help keep these potentially toxic materials out of the environment.

Also, attached are the flyer for the Saturday event for residents (same location). If you can help get the word out that would be much appreciated. The vendor's W9 form is also attached for those of you who may need to update your system.

Regards,

Ermin Siljkovic
Recycling Coordinator
Orange County DPW
Division of Environmental
Facilities & Services (EF&S).
2455-2459 Route 17M, P.O. Box 637
Goshen, NY 10924
(845) 291-3246 (Office)
(845) 637-9041 (Cell)
(845) 291-4570 (Fax)
esiljkovic@orangecountygov.com

This communication may contain confidential information and is intended only for the individual or entity to whom it is addressed. Any review, dissemination, or copying of this communication by anyone other than the intended recipient is strictly prohibited. If you are not the intended recipient, please contact the sender, and destroy all copies of the original message. No responsibility is accepted by Orange County Government for any loss or damage arising in any way from receiving this communication.

TOWN OF WARWICK



132 KINGS HIGHWAY
WARWICK, NEW YORK 10990

TOWN HALL TELEPHONE (845) 986-1127
POLICE DEPT. TELEPHONE (845) 986-3423
RECEIVER OF TAXES (845) 986-1125
PUBLIC WORKS TELEPHONE (845) 986-3358
TOWN HALL FAX (845) 986-3308
COMMISSIONER bastorino@townofwarwick.org
DPW CLERK dpw@townofwarwick.org

April 06, 2020

Michael P. Sweeton, Supervisor
Town of Warwick
132 Kings Highway
Warwick NY 10990

RECEIVED
APR 07 2020
Town of Warwick
Town Clerk

Re: Knight's Lane Request for Road Width Reduction

Dear Mr. Sweeton,

The Town received a letter from Lehman & Getz, P.C. dated March 23, 2020 requesting to reduce the proposed width of Knight's Lane from 30-ft to 24-ft and to convert a cul-de-sac into a T-turnaround. At the time of planning board approval (November 06, 2002), 30-ft wide public roadways were the standard widely used by municipalities. In 2005, our Town Code was updated to allow all proposed public roadways within subdivisions to be 24-ft wide. The conversation from a typical cul-de-sac into a T-turnaround will still allow a safe turnaround area for trucks and emergency vehicles but it will lessen the paved area required and make the area easier to plow in the winter months.

During a January 08, 2020 site inspection, it was apparent that reducing the width of Knight's Lane and reconfiguring the cul-de-sac will lessen ground disturbance and overall impacts to the property. Also, the reduced width and cul-de-sac conversion will lower future Town maintenance costs after the road is dedicated to the Town.

Sincerely,

Benjamin D. Astorino, Commissioner
Department of Public Works

Attachments (1): 1) 03/18/20 Knight's Lane Road Alternative Drawing (Lehman & Getz)

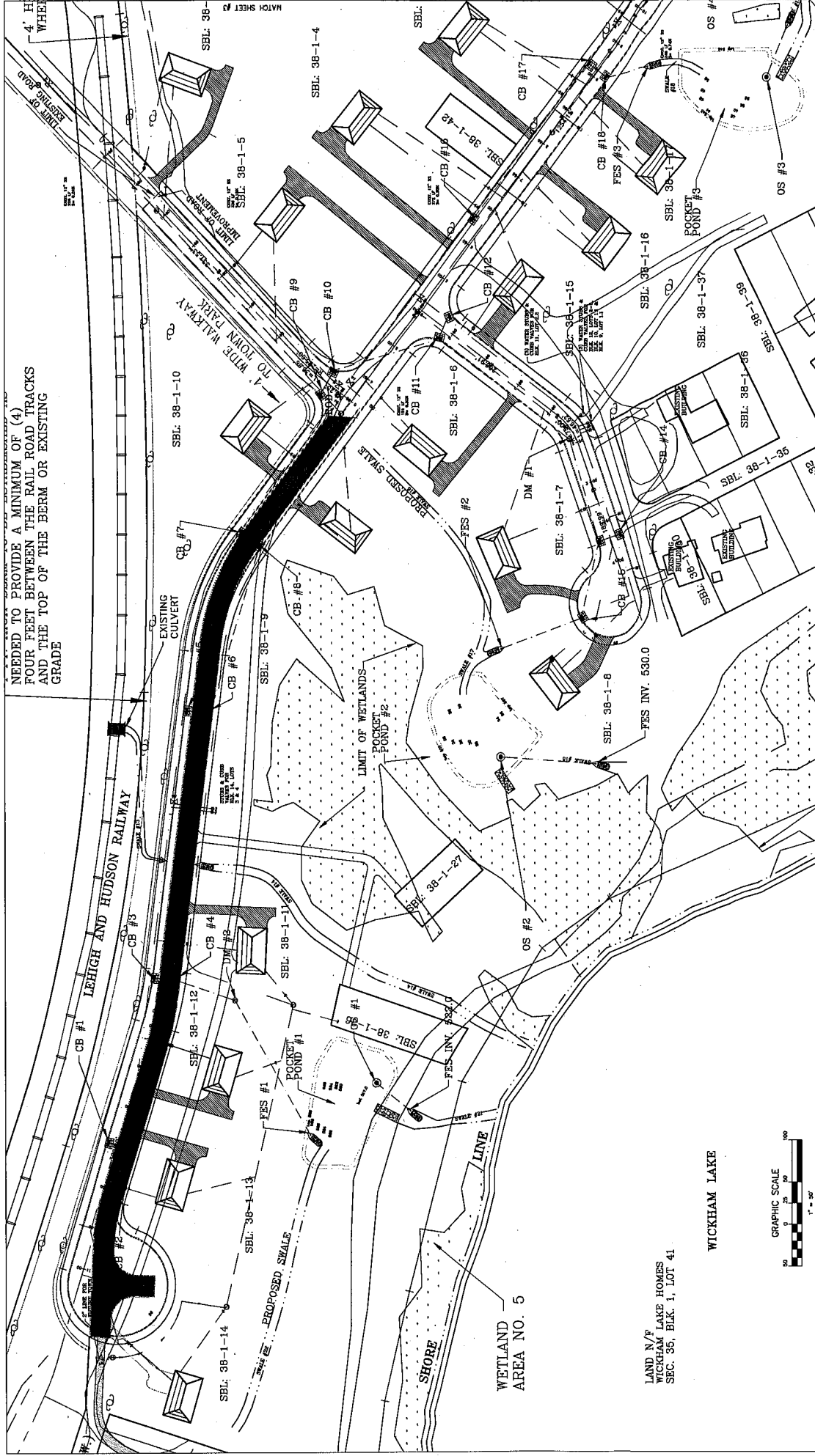

NEEDED TO PROVIDE A MINIMUM OF (4) FOUR FEET BETWEEN THE RAIL ROAD TRACKS AND THE TOP OF THE BERM OR EXISTING GRADE

STORMWATER REVISIONS
WICKHAM LAKE HOMES

TOWN OF WASHINGTON, WASHINGTON COUNTY, NEW YORK
 LEHMAN & GETZ, P.C.
 17 BRUCE STREET
 WASHINGTON, NEW YORK 10980

DATE: 3/22/05
 DRAWN BY: D.A. GELZ, P.E.
 CHECKED BY: D.A. GELZ, P.E.
 REVISIONS: 1" = 50'

PROFESSIONAL ENGINEER
 No. 10000
 STATE OF NEW YORK

NO. _____
 REVISIONS DESCRIPTION

LEGEND

- CONTOUR ELEVATION
- PROPOSED STORMWATER PIPE
- PROPOSED STORMWATER POND
- WETLAND LIMIT
- PROPOSED SHALE
- PROPOSED EXISTENT
- PROPOSED PROPERTY LINE
- PROPOSED BERM

GRAPHIC SCALE
 1" = 50'

Warwick Town Clerk

From: Canfield, Courtney <ccanfield@orangecountygov.com>
Sent: Tuesday, April 07, 2020 4:49 PM
To: ddecker@bloominggrove-ny.gov; lzappala@thetownofchester.org;
townclerk@cornwallny.gov; townclerk@townofcrawford.org; flostc@aol.com;
pgersbeck@townofgoshen.org; clerk@greenvilleny.org;
townofhamptonburgh@hvc.rr.com; jpatterson@highlands-ny.gov;
jnaumchik@middletown-ny.com; minisinktownclerk@gmail.com;
Maryellen@monroeny.org; tstickles@townofmontgomery.com;
clerk@townofmounthope.org; kallegra@newwindsor-ny.gov; lvitek@cityofnewburgh-
ny.gov; Town-clerk@townofnewburgh.org; gskjkj@gmail.com;
robinwaizenegger@portjervisny.gov; townclerk@tuxedogov.org;
townclerk@townofwallkill.com; Warwick Town Clerk; ksherlock10940@yahoo.com;
dspotvin@woodburyny.us; clerk@villageofsouthbloominggrove.com;
riveravc@frontiernet.net; cwierzbicki@villageoffloridany.org; vogclerk@frontiernet.net;
vcmgwl@yahoo.com; Jane Leake; Regina Taylor; vjohnson@villageofmaybrook.com;
clerk@villageofmonroe.org; Monserrate Rivera-Fernandez;
villageclerk@villageofotisville.com; Deborah Matthews; info@unionvilleny.org;
mkraus@villageofwalden.org; clerk@villageofwarwick.org; christine@washingtontown-
ny.gov; woodburyvillage@yahoo.com; clerk@cornwall-on-hudson.org
Cc: Green, David; Vandemark, Louise; Staltare, Bianca
Subject: Important - Election Law Changes and Updates to Calendar
Attachments: 2020 Presidential Primary Calendar v 04.03.2020 (V4).pdf; 2020 Political Calendar REV
04.06.2020 (EO202.13).pdf; 2020 Mail Check Correction Flyer.PDF

Good afternoon Clerks,

We hope you all are doing well and staying healthy.

We wanted to keep you updated on some changes to Elections for 2020.

- Mail Check Cards
- Presidential Primary Election Date Change
- State & Local Primary Information
- Village, School, Library Election Date Change
- Independent Nominating Petitions - *suspended*

Mail Check Cards: Please note that the yellow cards that were recently received by voters are sent out annually to verify voters' mailing addresses as a requirement of the NYS Election Law. These cards were sent to the post office by our printing vendor for mailing before we were notified of changes to the election calendar by Executive Order. Unfortunately, the cards were mailed to voters advising them of a Presidential Primary on April 28th which has since been moved to June 23rd. We have attached a flyer for your reference and ask you to post the attached flyer on your websites and social media accounts to assist us with notifying the voters of the recent change.

RECEIVED
APR 08 2020
Town of Warwick
Town Clerk

Presidential Primary Election Date Change: The election date of the Democratic Presidential Primary was officially moved to June 23. The updated political calendar is attached where you can see the new dates for filing absentee ballots applications. This election will only contain the names of those individuals who had previously been qualified to appear on the ballot on April 28, 2020.

State & Local Primary Information: The date for this Primary is also June 23. Please note that we will have a Countywide Primary for the following offices: County Court Judge and Family Court Judge on the Conservative, Working Families, Green, Libertarian, Independence and SAM party lines. All towns will be involved and we expect to give you further information concerning this election in May. For your reference, an updated political calendar is attached where you can review dates for registering to vote and filing absentee ballots applications for the June 23 State and Local Primary and the General Election.

Village, School, Library Election Date Change: Any school, library, or village election scheduled to take place in April or May of 2020 is hereby postponed until at least June 1, 2020, and subject to further directive as to the timing, location or manner of voting for such elections per Executive Order by the Governor.

Independent Nominating Petitions: Circulation, filing, and collection of any designating petitions, or independent nominating petitions for any office that would otherwise be circulated or filed pursuant to the Election Law, Education Law or any other consolidated law for any office commencing March 31, 2020 are hereby postponed.

We will keep you updated as things progress throughout this election season. Thank you for your patience and as always if you have any questions, please feel free to contact us.

Courtney Canfield Greene

Deputy Commissioner of Elections

Orange County Board of Elections

75 Webster Ave, PO Box 30

Goshen, NY 10924

Office Line: (845) 360-6507

Email: ccanfield@orangecountygov.com



Like us on Facebook!

This communication may contain confidential information and is intended only for the individual or entity to whom it is addressed. Any review, dissemination, or copying of this communication by anyone other than the intended recipient is

strictly prohibited. If you are not the intended recipient, please contact the sender, and destroy all copies of the original message. No responsibility is accepted by Orange County Government for any loss or damage arising in any way from receiving this communication.

ATTENTION VOTERS

The Presidential Primary will take place on June 23, 2020.

ORANGE COUNTY BOARD OF ELECTIONS
75 WEBSTER AVE.
PO BOX 30
GOSHEN NY 10924

RETURN SERVICE REQUESTED

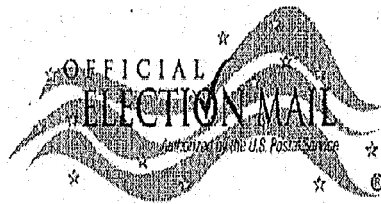

NON-PROFIT
U.S. POSTAGE
PAID
BUFFALO NY
PERMIT NO.1812

~~2020 Presidential Primary - April 28th, 2020~~

~~Polls open 6:00 AM until 9:00 PM~~

~~EARLY VOTING: April 18th - April 21, 2020*~~

~~You are eligible to vote 10 days before the April 28th, 2020 election~~

2020 June Primary - June 23rd, 2020

Polls open 6:00 AM until 9:00 PM

EARLY VOTING: June 13th - June 21, 2020*

You are eligible to vote 10 days before the June 23rd, 2020 election

2020 Presidential Election - Nov. 3rd, 2020

Polls open 6:00 AM until 9:00 PM

EARLY VOTING: October 24TH - November 1, 2020*

You are eligible to vote 10 days before the November 3rd, 2020 election

* For further information on times and location(s) of your Early Voting Site,
contact the Orange Board of Elections at (845) 360-6500 or visit our website at
www.orangecountygov.com/elections

Primarias presidenciales del 2020 - 28 de abril de 2020

Los centros de votación estarán abiertos de 6:00 AM a 9:00 PM

VOTACIÓN TEMPRANA: del 18 al 26 de abril de 2020*

Puede votar 10 días antes del 28 de abril en la elección del 2020

Primarias de junio del 2020 - 23 de junio de 2020

Los centros de votación estarán abiertos de 6:00 AM a 9:00 PM

VOTACIÓN TEMPRANA: del 13 al 21 de junio de 2020*

Puede votar 10 días antes del 23 de junio en la elección del 2020

Elección presidencial del 2020 - 3 de noviembre de 2020

ATTENTION VOTER
NYS HAS ADOPTED
EARLY VOTING

FOR FASTER CHECK-IN BRING THIS CARD
WITH YOU TO VOTE

ATENCIÓN, VOTANTE:
¡EL ESTADO DE NUEVA YORK HA ADOPTADO
LA VOTACIÓN TEMPRANA!
CUANDO VENGA A VOTAR TRAIGA ESTA
TARJETA PARA QUE SU PROCESO SEA MÁS
RÁPIDO

This political calendar is a ready reference to the significant dates pertaining to the Presidential Primary to be held in this State. For complete information consult the State's Election Law and Regulations and any relevant court orders.

All dates are based on statutory provisions in effect on the date of publication and may be subject to change. Final confirmation should be obtained from the State Board of Elections.

Filing Requirements: For 2020 Elections, except where otherwise required to be received by a date certain, all certificates and petitions of designation or nomination, certificates of acceptance or declination of such designations or nominations, certificates of authorization for such designations or nominations, certificates of disqualification, certificates of substitution for such designations or nominations and objections and specifications of objections to such certificates and petitions required to be filed with the State Board of Elections or a board of elections outside of the city of New York shall be deemed timely filed and accepted for filing if sent by mail or overnight delivery service, in an envelope postmarked or showing receipt by the overnight delivery service prior to midnight of the last day of filing, and received no later than two business days after the last day to file such certificates, petitions, objections or specifications. Failure of the post office or authorized overnight delivery service to deliver any such petition, certificate or objection to such board of elections outside the city of New York no later than two business days after the last day to file such certificates, petitions, objections or specifications shall be a fatal defect per NYS Election Law 1-106.

Within NYC: all such certificates, petitions and specifications of objections required to be filed with the board of elections of the city of New York must be actually received on or before the last day to file. The New York City Board of Elections is open for the receipt of such petitions, certificates and objections until midnight on the last day to file.



Calendar for the June 23, 2020

Rescheduled Presidential Primary Election for Selecting Delegates to a National Convention

**Requirements and dates herein are
provided for in Chapter 290 of
the Laws of 2019; Chapter 56
of the Laws of 2020 and
Executive Orders 202.12 and
202.13 of 2020**

**40 North Pearl Street, Suite 5
Albany, New York 12207
(518) 474-6220
www.elections.ny.gov**

March 31, 2020

Delegate Selection Plan

Pursuant to Chapters 290 of the Laws of 2019, a state committee providing for the selection of delegates and alternate delegates to a national party convention or conference must select either the \$3 plan or the \$4 plan contained in the act.

- 11/26/19 Last day for a party to select their delegate selection method. §2 Chapter 290 Laws of 2019
- 12/10/19 Last day for other political parties to choose Republican plan. §2-122-b(7)

Republican Delegate Selection Plan Filing Dates

- 1/07/20 – Dates for nationally known candidates or matching fund candidates to file certificate with State Board by 2/25/20 requesting to appear on ballot. §2-122-b(3)(a-b)
- Received by 2/25/20 Date for presidential candidate to file complete slate of delegates & alt. delegates. §2-122 b(4)(a)
- 3/3/20 Last day for SBOE to certify nationally known or matching fund candidates. §2-122-b(3)(b)
- Received by 3/3/20 Last day for presidential candidate to file certificate to have their name removed from the primary ballot. §2-122-b(3)(d)
- Received by 4/20/20 Last Day for presidential candidate to file certificate deeming any vote for such candidate to be a void vote. §2-122-b(3)(d)

Democratic Delegate Selection Plan Filing Dates

- 2/10/20 Last day for candidates to decline designations. §2-122-a(2) 4 days after last date to file petition
- 2/10/20 Last day for CBOE to notify SBOE of candidates which filed at CBOE. §2-122-a(6)(h)
- 2/18/20 Last day for party committee to file certificate of candidacies for delegate and alternate delegate candidates. §2-122-a(7)(a-b)
- 3/4/20 Last day for SBOE to notify party committee of candidates who will appear on ballot. §2-122-a(7)(d)
- 3/5/20 Last day for CBOEs to notify party committee of candidates who will appear on ballot. §2-122-a(7)(d)

5/8/2020 Last day for presidential candidate to announce withdrawal or suspension of campaign and/or indicate by letter to SBOE the such candidate no longer wishes to appear on primary ballot. §2-122(a)(13) added by Chap 56, Part TT of the Laws of 2020.

The Following Dates Apply to All Delegate Selection Plans:

Designating Petitions

- 12/31/19 First day for signing designating petitions. §6-134 (4)
- 2/3/20 - Dates for filing designating petitions. §6-158 (1)(a)
- 2/6/20
- 2/10/20 Last day to decline a designation. §6-158 (2)
- 2/14/20 Last day to fill vacancy after declination. §6-158 (3)

Certification

- 3/4/20 Certification of Primary ballot by SBOE of designations filed in its office. §4-110
- 3/5/20 Certification of Primary ballot by CBOE of designations filed locally. §4-114

Registration for Presidential Primary Election

- 5/29/20 **Mail Registration:**
Last day to postmark application; must be received no later than 6/3/20 by board of elections. §5-210 (3)
- 5/29/20 **In Person Registration:**
Last day application must be received by board of elections to be eligible to vote in primary election. §§5-210, 5-211 & 5-212
- 6/3/20 Change of address. §5-208 (3)

Absentee Voting for Presidential Primary Election

- 6/16/20 Last day to postmark application for ballot. §8-400 (2)(c)
- 6/22/20 Last day to apply in person for ballot. §8-400 (2)(c)
- 6/22/20 Last day to postmark ballot; must be received by the board of elections no later than 6/30/20. §8-412 (1)
- 6/23/20 Last day to deliver ballot in person to county board. §8-412 (1)

Military/Special Federal Voters for Presidential Primary Election

- 5/29/20 Last day for a BOE to receive application for ballot if not previously registered. §10-106 (5) & §11-202 (1)(a)
- 6/16/20 Last day for a BOE to receive application if previously registered. §10-106 (5) & §11-202(1)(b)
- 6/22/20 Last day to apply personally if previously registered. §10-106 (5)
- 5/8/20 Date for county boards to transmit Military/Special Federal ballots. §10-108 (1) & §11-204
- 6/22/20 Last day to postmark ballot; it must be received by the board of elections no later than 6/30/20. §10-114(1) & §11-212

Early Voting for Presidential Primary Election

- 3/16/20 Last day to designate early voting polling places, and their hours of operation for the Presidential Primary Election §8-600(4)(e)
- 6/13/20 - Days of Early Voting for the Presidential Primary Election §8-600 (1)
- 6/21/20

Presidential Electors

- 9/04/20 Last day for party committees to file certificate of party nomination of candidates for elector of President and Vice-President of the United States. §6-158 (6)(c)

2020 POLITICAL CALENDAR



Board of Elections

40 NORTH PEARL STREET – SUITE 5,
ALBANY, NEW YORK 12207 (518) 474-6220
For TDD/TTY, call the NYS Relay 711
www.elections.ny.gov

Primary Election General Election
June 23, 2020 November 3, 2020
Early Voting Dates for Primary

June 13 – June 21, 2020
Early Voting Dates for General Election
October 24 – November 1, 2020

This political calendar is a ready reference to the significant dates pertaining to elections to be held in this State. For complete information consult the State's Election Law and Regulations and any relevant court orders.

All dates are based on statutory provisions in effect on the date of publication and may be subject to change. Final confirmation should be obtained from your county board of elections or the State Board.

FILING REQUIREMENTS: For 2020 Elections, all certificates and petitions of designation or nomination, certificates of acceptance or declination of such designations or nominations, certificates of authorization for such designations or nominations, certificates of disqualification, certificates of substitution for such designations or nominations and objections and specifications of objections to such certificates and petitions required to be filed with the State Board of Elections or a board of elections outside of the city of New York shall be deemed timely filed and accepted for filing if sent by mail or overnight delivery service, in an envelope postmarked or showing receipt by the overnight delivery service prior to midnight of the last day of filing, and received no later than two business days after the last day to file such certificates, petitions, objections or specifications. Failure of the post office or authorized overnight delivery service to deliver any such petition, certificate or objection to such board of elections outside the city of New York no later than two business days after the last day to file such certificates, petitions, objections or specifications shall be a fatal defect per NYS Election Law §1-106.

Within NYC: all such certificates, petitions and specifications of objections required to be filed with the board of elections of the city of New York must be actually received on or before the last day to file. The New York City Board of Elections is open for the receipt of such petitions, certificates and objections until midnight on the last day to file.

ABSENTEE VOTING FOR GENERAL ELECTION

Oct. 27	Last day to postmark application or letter of application for general election ballot. §8-400(2)(c)
Nov. 2	Last day to apply in person for general election ballot. §8-400(2)(c)
Nov. 2	Last day to postmark general election ballot. Must be received by the county board no later than Nov. 10 th . §8-412(1)
Nov. 3	Last day to deliver general election ballot in person to county board, by close of polls on election day. §8-412(1)

MILITARY/SPECIAL FEDERAL VOTERS FOR GENERAL

Sept 18	Deadline to transmit ballots to eligible Military/Special Federal voters. §10-108(1) & §11-204(4)
Oct. 9	Last day for a board of elections to receive application for Special Federal absentee ballot for general if not previously registered. §11-202(1)(a)
Oct. 24	Last day for a board of elections to receive application for Military absentee ballot for general if not previously registered. §10-108(5)
Oct. 27	Last day for a board of elections to receive application for Military/Special Federal absentee ballot for general if already registered. §10-106(5) & §11-202(1)(b)
Nov. 2	Last day to apply personally for a Military absentee ballot for general if previously registered. §10-106(5)
Nov. 2	Last day to postmark Military/Special Federal ballot for general. Date by which it must be received by the board of elections is Nov. 16 th . §10-114(1) & §11-212

FINANCIAL DISCLOSURE

PRIMARY ELECTION §14-108(1)	
32 Day Pre-Primary	May 22
11 Day Pre-Primary	June 12
10 Day Post Primary	July 3
24 Hour Notice §14-108(2)	June 9 through June 22

GENERAL ELECTION §14-108(1)	
32 Day Pre-General	October 2
11 Day Pre-General	October 23
27 Day Post-General	November 30
24 Hour Notice §14-108(2)	October 20 through November 2

Periodic Reports §14-108(1)	
January 15 th	
July 15 th	

Additional Independent Expenditure Reporting	
24 Hour Notice §14-107(3) (b) & (c)	Primary: May 24 through June 22 General: October 4 through November 2
Weekly Notice	Refer to §14-107(3)(b)

*****VOTER REGISTRATION*****

VOTER REGISTRATION FOR PRIMARY

May 29	Mail Registration for Primary: Last day to postmark application for primary; last day it must be received by board of elections is June 3. §5-210(3)
May 29	In person registration for Primary: Last day application must be received by board of elections to be eligible to vote in primary election. §5-210, 5-211, 5-212
June 3	Changes of address for Primary received by this date must be processed. §5-208(3)

CHANGE OF ENROLLMENT

Change of Enrollments are effective immediately, except for those filed between Feb. 15th-June 30th; Change of Enrollments filed between Feb. 15th-June 30th, will take effect on June 30th.

VOTER REGISTRATION FOR GENERAL

Oct. 9	Mail Registration for General: Last day to postmark application for general election; it must also be received by board of elections by Oct. 14. §5-210(3)
Oct. 9	In person registration for General: Last day application must be received by board of elections to be eligible to vote in general election. If honorably discharged from the military or have become a naturalized citizen since October 10 th , you may register in person at the board of elections up until October 24 th . §5-210, 5-211, 5-212
Oct. 14	Changes of address for General received by this date must be processed. §5-208(3)

Oct. 4	First day for local registration. §5-202(1)
TBD	Uniform day for local registration throughout the state. §5-202(3)

*****VOTING BY ABSENTEE*****

ABSENTEE VOTING FOR PRIMARY

June 16	Last day to postmark application for primary ballot. §8-400(2)(c)
June 22	Last day to apply in person for primary ballot. §8-400(2)(c)
June 22	Last day to postmark ballot. Must also be received by county board no later than June 30 th . §8-412(1)
June 23	Last day to deliver primary ballot in person to county board, by close of polls. §8-412(1)

MILITARY/SPECIAL FEDERAL VOTERS FOR PRIMARY

May 8	Deadline to transmit ballots to eligible Military/Special Federal Voters. §10-108(1) & §11-204(4)
May 29	Last day for a board of elections to receive application for Military/Special Federal absentee ballot for primary if not previously registered. §10-106(5) & §11-202(1)(a)
June 16	Last day for a board of elections to receive application for Military/Special Federal absentee ballot for primary if already registered. §10-106(5) & §11-202(1)(b)
June 22	Last day to apply personally for Military ballot for primary if previously registered. §10-106(5)
June 22	Last day to postmark Military/Special Federal ballot for primary. Date by which it must be received by the board of elections is June 30 th . §10-114(1) & §11-212

***** ELECTION DATES****

June 23	Primary Election §8-100(1)(e)
June 13- June 21	Days of Early Voting for the Primary Election. §8-600(1)

Feb 1	Certification of offices to be filled at 2020 general election by SBOE and CBOE. §4-106 (1&2)
Feb 11	PARTY CALLS: Last day for State & County party chairs to file a statement of party positions to be filled at the Primary Election. §2-120

CERTIFICATION OF PRIMARY

April 29	Certification of primary ballot by SBOE of designations filed in its office. §4-110
April 30	Determination of candidates; County Boards. §4-114

CANVASS OF PRIMARY RESULTS

July 6	Canvass of Primary returns by County Board of Elections §9-209(1)
July 6	Verifiable Audit of Voting Systems. §9-211(1)
July 13	Recanvass of Primary returns. §9-208(1)

Nov. 3	General Election §8-100(1)(c)
Oct. 24 - Nov. 1	Days of Early Voting for the General Election. §8-600(1)

CERTIFICATION OF GENERAL ELECTION BALLOT

Sept. 9	Certification of general election ballot by SBOE of nominations filed in its office. §4-112(1)
Sept. 10	Determination of candidates and questions; County Boards. §4-114

CANVASS OF GENERAL ELECTION RESULTS

Nov. 18	Recanvass of General Election returns to occur no later than Nov. 18. §9-208(1)
Nov. 18	Verifiable Audit of Voting Systems to occur no later than Nov. 18. §9-211(1)
Nov. 28	Certification and transmission of Canvass of General Election returns by County Board of Elections §9-214
Dec. 7	State Board of Canvassers meet to certify General Election. §9-216(2)

**** BECOMING A CANDIDATE*****

DESIGNATING PETITIONS FOR PRIMARY
(As amended by Chapter ___ of the Laws of 2020)

Feb 25	First day for signing designating petitions. §6-134(4)
Mar 17- Mar 20	Dates for filing designating petitions. §6-158(1)
Mar 24	Last day to authorize designations. §6-120(3)
Mar 24	Last day to accept or decline designations. §6-158(2)
Mar 30	Last day to fill a vacancy after a declination. §6-158(3)
April 3	Last day to file authorization of substitution after declination of a designation. §6-120(3)

OPPORTUNITY TO BALLOT PETITIONS
(Pursuant to Executive Order 202.2 of 2020, Opportunity-to-Ballot Petitions have been suspended for 2020.)

PARTY NOMINATION OTHER THAN PRIMARY

Feb 4- Feb 25	Dates for holding state committee meeting to nominate candidates for statewide office §6-104(6)
Feb 25	First day to hold a town caucus. §6-108
July 23	Last day for filing nominations made at a town or village caucus or by a party committee. §6-158(6)
July 23	Last day to file certificates of nomination to fill vacancies created pursuant to § 6-116, §6-104 & §6-158(6)
July 27	Last day to accept or decline a nomination for office made based on § 6-116 & §6-158(7)
July 27	Last day to file authorization of nomination made based on § 6-116. § 6-120(3)
July 30	Last day to fill a vacancy after a declination made based on § 6-116. § 6-158(8)

INDEPENDENT PETITIONS

(Pursuant to Executive Order 202.13, the circulation and filing of Independent Nominating Petitions has been postponed beginning March 31, 2020 until further notice.)

Apr 14	First day for signing nominating petitions. §6-138(4)
May 19 - May 26	Dates for filing independent nominating petitions. §6-158(9)
May 29	Last day to accept or decline nomination. §6-158(11)
June 1	Last day to fill a vacancy after a declination. §6-158(12)
June 26	Last day to decline after acceptance if nominee loses party primary. §6-158(11)

JUDICIAL DISTRICT CONVENTIONS

Minutes of a convention must be filed within 72 hours of adjournment. §6-158(6)

Aug 6 - Aug 12	Dates for holding judicial conventions. §6-158(5)
Aug 13	Last day to file certificates of nominations. §6-158(6)
Aug 17	Last day to decline nomination. §6-158(7)
Aug 21	Last day to fill vacancy after a declination. §6-158(8)

MEMBER OF COUNTY COMMITTEE

Amended by Chapter 18 of the Laws of 2019

For any party position of member of the ward, town, city or county committee, petitions must be signed by not less than 3% of the then enrolled voters of the party residing within the election district for which the position is to be voted. § 6-136(2)(f)

SIGNATURE REQUIREMENT FOR DESIGNATING AND OPPORTUNITY TO BALLOT PETITIONS

Pursuant to Executive Order 202.2 of 2020, 1.5% of the active enrolled voters of the political party in the political unit or the following, whichever is less:

For any office to be filled by all the voters of: the entire state.....	4,500
(with at least 30 or 1.5% of enrolled voters from each of one-half of the congressional districts)	
New York City.....	2,250
any county or borough of New York City.....	1,200
a municipal court district within NY City.....	450
any city council district within New York City.....	270
cities or counties having more than 250,000 inhabitants.....	600
cities or counties having more than 25,000 but not more than 250,000.....	300
any other city, county, councilmanic or county legislative districts in any city other than NY City.....	150
any congressional district.....	375
any state senatorial district.....	300
any assembly district.....	150

any political subdivision contained within another political subdivision, except as herein provided, requirement is not to exceed the number required for the larger subdivision; a political subdivision containing more than one assembly district, county or other political subdivision, requirement is not to exceed the aggregate of the signatures required for the subdivision or parts of subdivision so contained.

*NOTE: Section 1057-b of the New York City Charter supersedes New York Election Law signature requirements for Designating and OTB petitions and Independent nominating petitions with respect to certain NY City offices.

SIGNATURE REQUIREMENT FOR INDEPENDENT NOMINATING PETITIONS

5% of the total number of votes, excluding blank and void, cast for the office of governor at the last gubernatorial election in the political unit, except that not more than 3,500 signatures shall be required on a petition for any office to be filled in any political subdivision outside the City of New York, and not more than the following for any office to be voted for by all the voters of:

the entire state.....	45,000
(with at least 500 or 1% of enrolled voters from each of one-half of the congressional districts) (Part V Public Financing Commission Recommendations)	
any county or portion thereof outside the city of NY.....	1,500
the City of New York.....	7,500
any county or borough or any two counties or boroughs within the city of NY City.....	4,000
a municipal court district.....	3,000
any city council district within NY City.....	2,700
any congressional district.....	3,500
any state senatorial district.....	3,000
any assembly district.....	1,500

any political subdivision contained within another political subdivision, except as herein provided, requirement is not to exceed the number required for the larger subdivision.

Warwick Town Clerk

From: Bonnie Becker <bbecker@nytowns.org>
Sent: Monday, April 06, 2020 11:55 AM
Subject: Vol. 4 AOT's Legislative Newsletter
Attachments: Volume 4 In Session.pdf

Attached is a copy of AOT's 2020/2021 Budget Summary. We ask that you share it with town board members. There is a lot of uncertainty as a result of the ongoing health crisis, but we would like to assure you that AOT is working tirelessly to advocate for local governments and assist you in finding answers. In the meantime, we ask that you please fill out this [fiscal impact survey](#) developed by the National Association of Towns and Townships to use in advocating for direct funding to local governments from the federal government.

Be safe and stay healthy.

RECEIVED

APR 06 2020

Town of Warwick
Town Clerk

IN SESSION

Association Of Towns' Legislative Newsletter



In this Issue

- **A Note to our Members during COVID-19**
- **Budget Items Affecting Towns**
- **Items Omitted from State Budget**

On April 2, the New York State Budget was adopted for state fiscal year 2020-2021. To say this year's budget and budget process has been unusual would be an understatement. From the time the Executive Budget was released through mid-March, AOT was meeting with lawmakers and their staffs, conferencing with interested parties, and preparing for the one-house budget bills to be released. Then the world turned upside down.

With the ongoing health crisis and an uncertain financial future, this year's budget leaves more questions than answers. The priority right now is, and should be, public health and safety. The Division of Budget will periodically review state revenue and expenditures and may adjust or reduce appropriations accordingly (see Balanced Budget Amendment below). This, combined with reduced sales tax revenue, permitting fees, mortgage recording tax etc., undoubtedly stresses your ability to budget, particularly as you continue to provide essential services and help your community. While there are many unknowns at this point, we continue to have ongoing contact with the Governor's office, Comptroller DiNapoli, lawmakers, and various state agencies letting them know the impact COVID-19 is having on local governments. As we receive clarification or guidance on issues related to or impacting local governments, we will update you. Meanwhile, we encourage you to reach out to our office with your concerns and questions so that we may help where we can and relay other issues to the state.

What follows is a summary of some key provisions in the final state budget

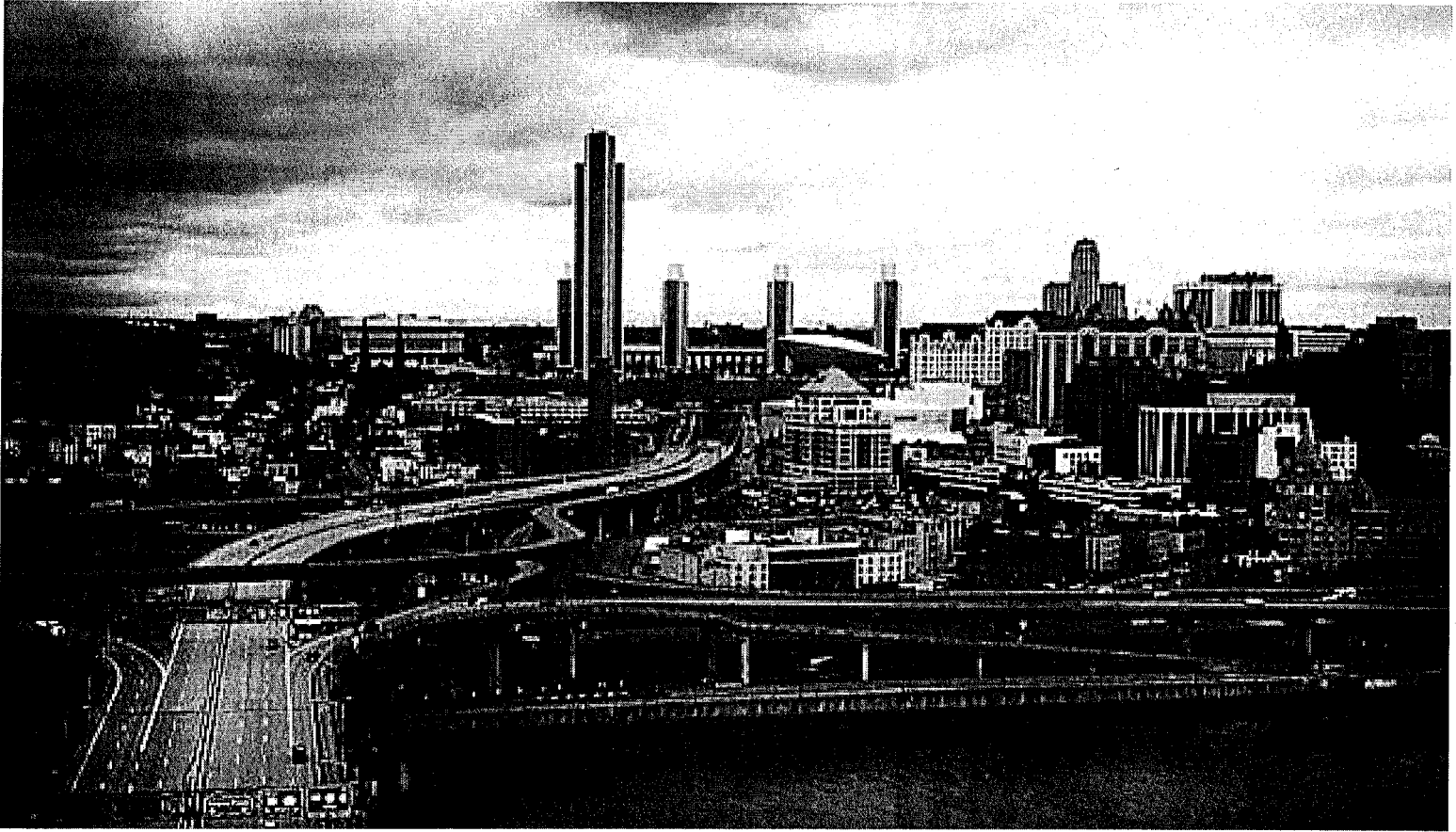

impacting local governments. We, and by extension our members, are proud to have achieved some victories for local government with this budget; small cell wireless being permitted to the detriment of home rule is OUT; get discovery and bail reform, along with funding and changes to the list of excepted crimes is IN; and we are proud to have achieved some significant compromises to the siting of renewable energy legislation. However, we suspect that our work is far from over. The Legislature passed a resolution allowing members to vote remotely if needed, and we anticipate the Legislature will conduct a special session later this year. We will continue our advocacy and make sure our members have the information and tools needed to speak with your individual representatives.

[The Balanced Budget Amendment] combined with reduced sales tax revenue, permitting fees, mortgage recording tax etc., undoubtedly stresses your ability to budget, particularly as you continue to provide essential services and help your community.

Seeing the response by local governments during this unprecedented time makes us proud to work with and represent towns. Though we are working from home for the foreseeable future, AOT's commitment to helping towns remains unwavering. We encourage you follow us on Facebook and Twitter, where we post up-to-date information, check our website nytowns.org for additional informational postings, and to contact us via e-mail (info@nytowns.org) with any questions or areas of need where we can provide a resource (chances are, if one of our members has a question, other members do too!). You may also call our office at (518)465-7933 and leave a voicemail; someone will get back to you.

You may also call our office at (518)465-7933 and leave a voicemail; someone will get back to you. We hope you and your loved ones stay safe and healthy.

Balanced Budget Amendment (S7506-B/ A 9506-B ELFA Part JJ)

- Requires the state budget director to review state revenues and expenditures during three measurement periods to determine whether the state budget is balanced
 - Three measurement periods are (1) April 1 to April 30, 2020, (2) May 1 to June 30, 2020, and (3) July 1 to Dec. 31, 2020
- Authorizes the state budget director to "adjust or reduce any general fund and/or state special revenue fund appropriation and related cash disbursement by any amount needed to maintain a balanced budget" for state fiscal year 2020-2021. There are certain exceptions, and cuts should be as uniform as possible.
- Legislature has 10 days to adopt its own balanced budget plan. The state budget director may implement his or her own plan if the Legislature fails to adopt its own plan within the designated time

Highway Funding Remains Flat (Capital Funding Appropriation Bill S7504-c/A9504-c)

- \$438.1 million for Consolidated Highway Improvement Program (CHIPS) (p. 607)
- \$39.7 million for the Marchiselli program (p. 606)
- \$100 million for the PAVE-NY program
- \$100 million for the BridgeNY program
- Extreme Winter Recovery Funding \$65 million

NOTE – these funds are subject to the Balanced Budget Amendment (see above), and the Division of Budget must first certify that the state can distribute/spend this money without adversely impacting state funding for capital projects deemed essential to public health and safety or essential government services.

Renewable Energy Siting (S7508-B/ A 9508-B TED Part JJJ)

- Creates the Office of Renewable Energy Siting to permit renewable energy projects with a capacity of 20KW or more
- Establishes a new process to site renewable energy projects
- Authorizes NYSERDA to facilitate build-ready sites with an emphasis on brownfields and other underutilized properties

NOTE – The Association of Towns will be sending out a separate informational sheet outlining the new process and providing more details

Aid and Incentives to Municipalities (AIM) General Purpose Revenue Sharing

- AIM and AIM-related payments remain the same as last year (Aid to Localities Budget Appropriation, page 942)
- Addresses the authority for the financial control boards in Erie and Nassau counties to turn over sales taxes to the state comptroller in order to meet their AIM-related sales tax payments (S7505-B/ A9505-B, PPGG Part NN)

NOTE - AIM payments, and potentially AIM-related payments, are subject to the Balance Budget Amendment (see above)

Increase in mandatory competitive bidding threshold for CHIPS funded projects (S7508-B/ A 9508-B TED Bill Part A)

- Amends Highway Law § 10-c (4) to increase the monetary threshold from \$250,000 to \$350,000 before a town will be required to competitively bid a public works project funded by CHIPS
- Please note that public works projects that exceed \$35,000 are still subject to competitive bidding if the town decides to contract for the project instead of using the town highway department employees

Restore Mother Nature Bond Act (S7508-B/ A 9508-B, TED Part QQ and RR)

- Allows an aggregate of \$3 billion in state debt to be created and used as follows
 - \$1 billion for restoration and flood risk reduction
 - \$550 for open space conservation and recreation
 - Up to \$700 million for climate change mitigation
 - Not less than \$550 million for water quality improvement and resilient infrastructure
- Subject to voter approval at the November 2020 elections; however, it will not be submitted unless the Division of Budget certifies to the Secretary of State that the debt can be issued within the state's financial plan without adversely affecting funding available for capital projects essential to the health and safety of the public or essential government services
- If the act does not get submitted to voters in November, it will be deemed expired
- If approved, the DEC will distribute funds and promulgate regulations on how municipalities can apply for funds

Prevailing Wage Expansion (S7508-B/ A 9508-B TED Part FFF)

- Amends Labor Law to expand prevailing wage requirements to more projects
- Creates a state subsidy board made up of agency heads, industry groups and labor groups that can clarify application of \ new prevailing wage requirements and determine exemptions
- Prevailing wage now required for private construction projects when the project costs over \$5 million and at least 30 percent of it is paid by public funds
 - exceptions for certain affordable housing projects and renewable energy projects

E-Scooters and Bikes

- Authorizes electronic scooters and electronic bicycles on municipal roadways and grants localities the ability to further regulate or prohibit electronic scooters and bicycles within their jurisdictions
- Towns in Westchester, Nassau and Suffolk counties may prohibit e-scooters and e-bikes but cannot further regulate them without county authorization

Removal of STAR Benefit for Past-Due Taxes (ELFA Part W)

- Removes the STAR benefit for any taxpayer that has past-due taxes
- Town officials will be required to implement this policy and notify the state of any delinquent taxpayers.

Election Recounts (S7505-B/ A9505-B, PPGG Part JJ)

- Requires an automatic manual recount of election results when there is a slim margin of victory (0.2 percent or less in elections for statewide offices and 0.5 percent or less in non-state wide elections)
- Goes into effect January 1, 2021 and applies to any election held 120 days or more after the effective date

Add "E Pluribus Unum" (Out of Many, One) to the State Arms (S7508-B/ A 9508-B TED Part U)

- Adds state motto "E Pluribus Unum" to the word "Excelsior" on the scroll beneath the shield agent which appears on the state seal and the state flag. Effective 180 days after April 2, 2020, and within 60 days any electronic depiction of the arms of the state must be updated.
- Local governments are not required to replace a flag solely because it contains the former arms of the state.

Notaries (S7508-B/ A 9508-B TED Part V)

- Notary publics no longer need to be U.S. citizens. They must still be either a resident of New York or have an office or place of business in New York. Effective immediately.

Water Funding (S7508-B/ A 9508-B TED Part KK)

- Amends Public Authorities Law § 1285-j (4) to allow the Environmental Facilities Corporation to offer municipalities 40-year financing through the Clean Water State Revolving Fund and/or Drinking Water State Revolving Fund for projects which qualify for zero-percent interest rates due to financial hardship.

Effective immediately.

Bans Styrofoam Container and Packing Peanuts (S7508-B/ A 9508-B TED Part PP)

- Bans food service providers and stores from selling, distributing or using Styrofoam and packing peanuts to hold food or beverage
- Towns are pre-empted from adopting local laws on the issue

Optional Exemption from Special Ad Valorem Levies (PPGG Part XX Subpart E)

- Provides towns with the ability to provide taxpayers with a real property tax exemption for any improvements to residential real property that facilitates accessibility for a physically disabled owner

Union Access to Employee Orientation Training PPGG Part W:

- Requires public employers to provide unions access to new employee orientations if the public employer conducts such orientations

Prison Closures (PPGG Part F)

- Provides the Governor with the authority to close correctional facilities in Fiscal Year 2020-2021 as he determines necessary for cost-saving measures, so long as he provides 90 days' notice to the temporary president of the senate and the speaker of the assembly

Establishes the District Attorney Discovery Compensation Fund (PPGG Part E)

- Creates the District Attorney Discovery Compensation Fund (funded at \$40 million) to support expenses related to digital evidence transmission technology, administrative support, computers, hardware and operating software, data connectivity, development of training materials, staff training, overtime costs, litigation readiness, and pretrial services.
- Counties, cities with populations less than 1 million, and law enforcement and prosecutorial entities within towns and villages are eligible for these funds

Discovery and Bail Reform (ELFA Parts UU and HHH)

- Expands list of crimes are eligible for bail
- Extends timeline for discovery
 - 20 days from arraignment if defendant is in custody while criminal case is pending
 - 35 days from arraignment if defendant is not in custody while criminal case is pending
 - As soon as possible but no later than 15 days before trial for a vehicle and traffic infraction or a petty offense (as defined in a municipal code) that does not carry a sentence of imprisonment

Omitted from the Final Budget

- Legalizing recreational use cannabis
- Proposal on permitting of small cell wireless facilities
- Proposal to eliminate video lottery terminal aid
- Proposed amendment to allow more flexibility in projects eligible for state matching funds under the county-wide shared services matching savings grant program
- Proposal on the disclosure of tax returns for certain local elected officials
- Court restructuring proposal
- Amending interest rates on judgments

An Announcement Re: Our 2020 Finance Schools

Unfortunately, due to COVID-19, we are forced to postpone our original training event. We will announce the new dates and locations as soon as we have them, and we sincerely hope you will be able to join us. We hope you and yours are staying safe during these uncertain times.

As always, please stay tuned to our website, nytowns.org, and our social media, as well as your inbox and your mailbox, for important communications.

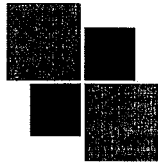

LEHMAN & GETZ
CONSULTING ENGINEERS

cc
T/Clerk ✓
T/TBD ✓
Ben A. ✓

March 23, 2020

Supervisor Michael Sweeton
Town of Warwick Town Board
132 Kings Highway
Warwick, NY 10990

*Need letter
from Ben A.*

Re: Wise Equities LLC Property
Knights Lane
Wickham Lake Estates Subdivision
L&G #2421

Dear Supervisor Sweeton and Town Board Members:

We request your approval of a modification of the required road width for the proposed road construction of Knights Lane, a road that was approved as part of the Wickham Lake Estates Subdivision. Wise Equities LLC has purchased a portion of the subdivision, and plans to build the road and five new residences.

A paved road width of thirty feet is shown on the approved subdivision plans. We request approval of a reduced width of twenty-four feet. We feel that the reduced width is consistent with the limited number of lots along the road and with the Town's goals to reduce runoff, maintenance costs, and ground disturbance. I have discussed the situation with Ben Astorino and Laura Barca, and they indicated that they are supportive of the revision.

Thank you for your consideration.

Sincerely,

David A. Getz
Lehman & Getz, P.C.
David A. Getz, P.E.

cc: David Ungar
Wise Equities, LLC
Ben Astorino
Laura Barca, P.E.

RECEIVED
APR 08 2020
Town of Warwick
Town Clerk

RECEIVED
MAR 27 2020
TOWN OF WARWICK
SUPERVISOR'S OFFICE